

# PAC-TITE GOLD COPING ENDCAPS

WELDED POST-FINISHED ENDCAP ASSEMBLY

STANDARD ENDCAP LENGTH IS 18"

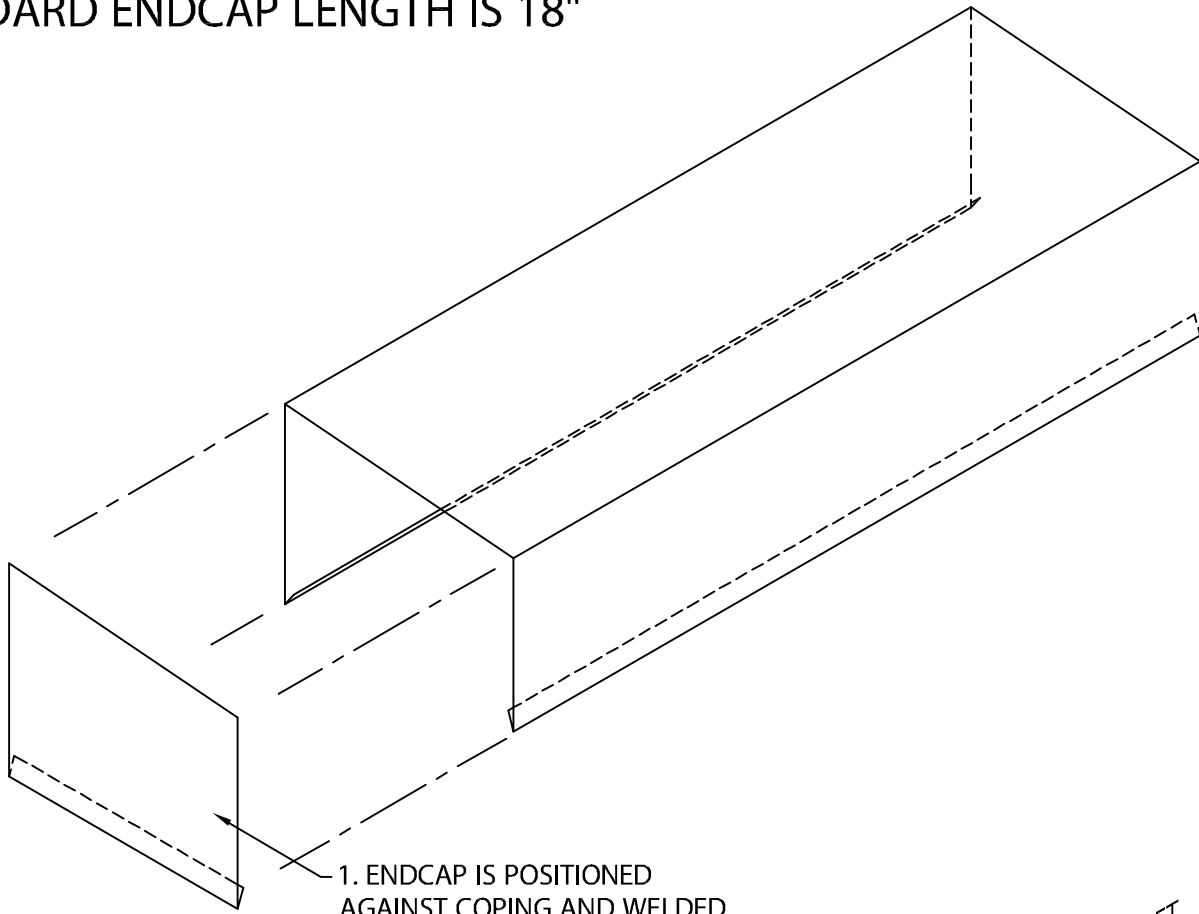

2. PIECE IS POST-COATED AFTER FABRICATION AND WELDING

OUTSIDE FACE

LEFT ENDCAP

INSIDE FACE

WELDED ENDCAPS ARE FABRICATED WITH FULLY WELDED OUTSIDE CORNERS



Phone: 800-323-1960 Fax: 800-722-7150  
www.pac-clad.com  
e-mail: info@pac-clad.com

DATE: 03/04/15  
DRN BY: JJC  
CKD BY: SAK

SHT.# \_\_\_ OF \_\_\_  
DWG# 41511-21347

A