

PAC-200 PANEL PROFILE

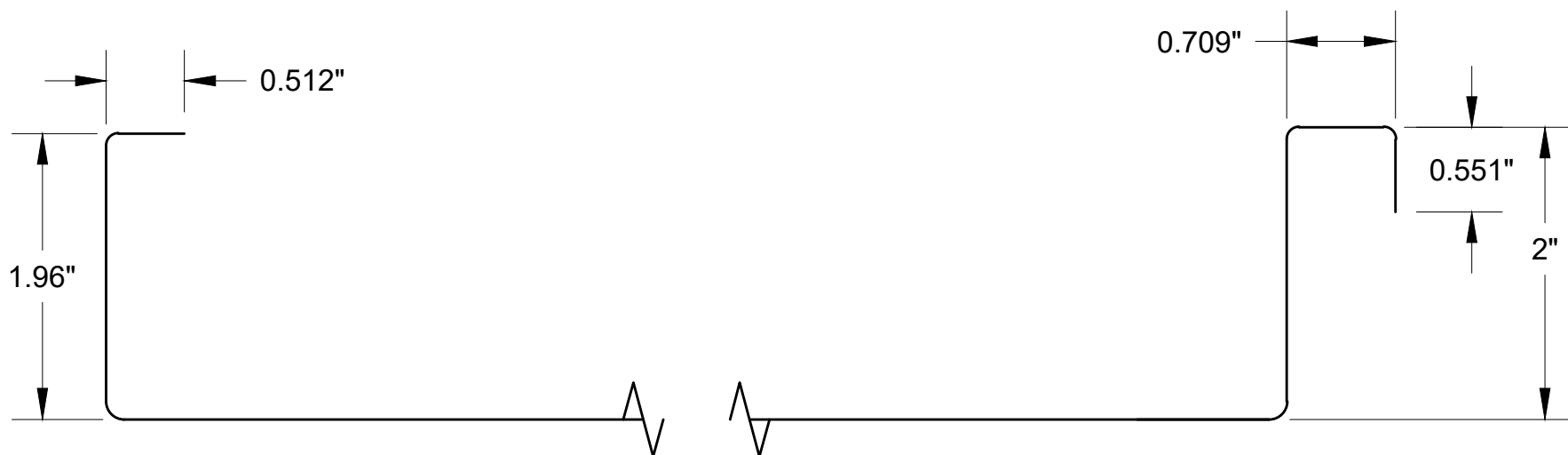

(Stiffening Ribs, Striations, & Clip Reliefs are Optional)



PAC-200 FLASHING DETAILS

HIP / RIDGE DETAIL

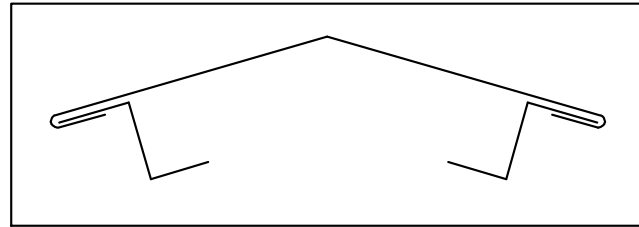

FLASHING COMPONENTS

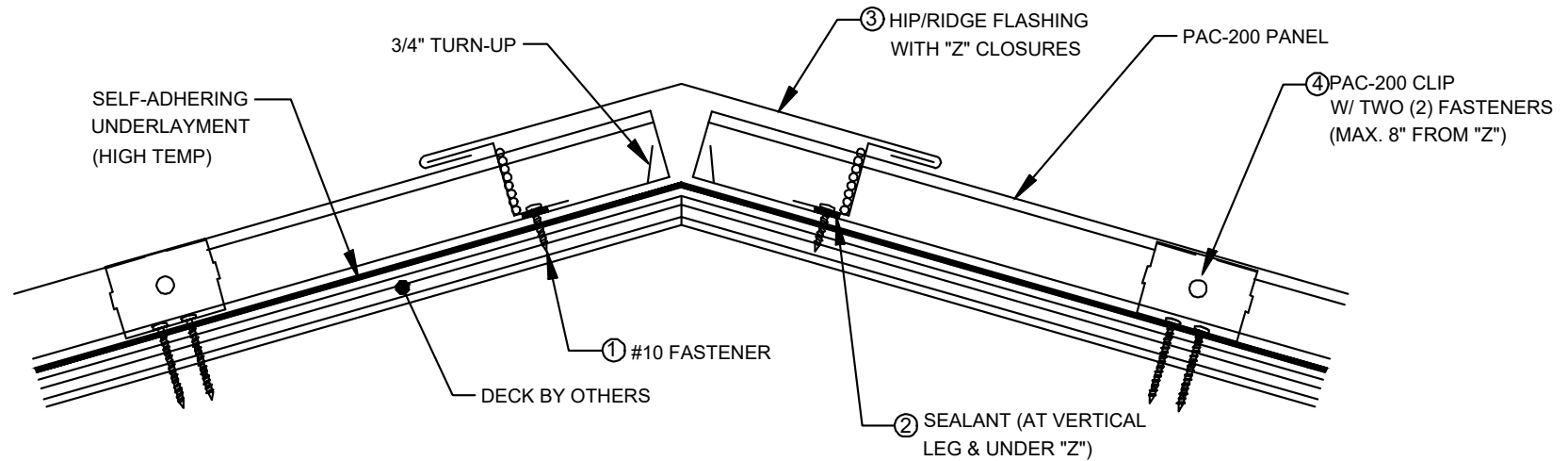

KEYNOTES:

- TRIM FASTENERS ARE SELF-DRILL PANCAKE HEAD AND MUST BE INSTALLED IN A STAGGERED PATTERN.
- CLIP AND FASTENER MATERIAL: GALVANIZED WHEN STEEL PANELS ARE UTILIZED; STAINLESS STEEL WHEN ALUMINUM PANELS ARE UTILIZED.
- CLIP FASTENERS MUST BE OF SUFFICIENT LENGTH TO PENETRATE PLYWOOD DECK BY 5/8" MINIMUM THREAD LENGTH.
- PLYWOOD DECK MUST BE A MINIMUM OF 5/8" THICK.

① "Z" COMPONENT

- MINIMUM HEIGHT: 1/8" CLEARANCE OF PANEL RIB
- FASTENED AS FOLLOWS: 12" & 16" PANELS (4 FASTENERS PER PANEL MINIMUM); 18" PANELS (6 FASTENERS PER PANEL MINIMUM)
- FASTENING LEG: 1 1/4" MINIMUM TOP LEG: 1 1/2" MINIMUM
- "Z" MUST BE CUT TO TIGHT FIT OF PANEL DIMENSION: 1/8" MAXIMUM GAP

② SEALANT

- TUBE OR TAPE SEALANT IS ACCEPTABLE BELOW THE "Z"
- TUBE SEALANT PLACED AT BACKSIDE OF VERTICAL LEGS
- 1" TAPE WIDTH OR 1/2" BEAD WIDTH PRIOR TO COMPRESSION

③ COVER: HEMMED 1" AND FULLY ENGAGED TO "Z" CLOSURE.

④ FIRST PANEL CLIP TO BE LOCATED A MAXIMUM OF 8" FROM "Z" COMPONENT.



PAC-200 FLASHING DETAILS

VENTED RIDGE DETAIL

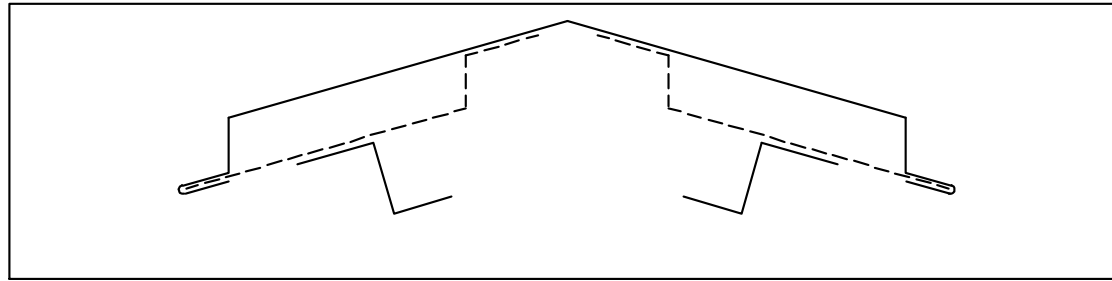

FLASHING COMPONENTS

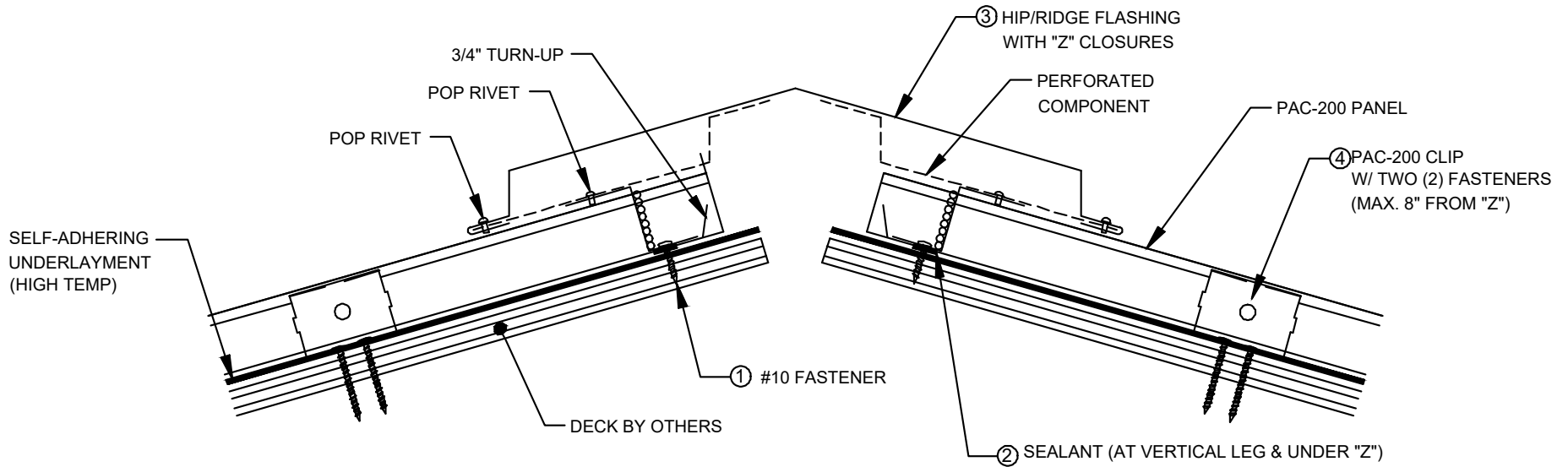

KEYNOTES:

- TRIM FASTENERS ARE SELF-DRILL PANCAKE HEAD AND MUST BE INSTALLED IN A STAGGERED PATTERN.
- CLIP AND FASTENER MATERIAL: GALVANIZED WHEN STEEL PANELS ARE UTILIZED; STAINLESS STEEL WHEN ALUMINUM PANELS ARE UTILIZED.
- CLIP FASTENERS MUST BE OF SUFFICIENT LENGTH TO PENETRATE PLYWOOD DECK BY 5/8" MINIMUM THREAD LENGTH.
- PLYWOOD DECK MUST BE A MINIMUM OF 5/8" THICK.

- ① "Z" COMPONENT
 - MINIMUM HEIGHT: 1/8" CLEARANCE OF PANEL RIB
 - FASTENED AS FOLLOWS: 12" & 16" PANELS (4 FASTENERS PER PANEL MINIMUM); 18" PANELS (6 FASTENERS PER PANEL MINIMUM)
 - FASTENING LEG: 1 1/4" MINIMUM TOP LEG: 1 1/2" MINIMUM
 - "Z" MUST BE CUT TO TIGHT FIT OF PANEL DIMENSION: 1/8" MAXIMUM GAP
- ② SEALANT
 - TUBE OR TAPE SEALANT IS ACCEPTABLE BELOW THE "Z"
 - TUBE SEALANT PLACED AT BACKSIDE OF VERTICAL LEGS
 - 1" TAPE WIDTH OR 1/2" BEAD WIDTH PRIOR TO COMPRESSION
- ③ COVER: HEMMED 1" AND FULLY ENGAGED TO "Z" CLOSURE.
- ④ FIRST PANEL CLIP TO BE LOCATED A MAXIMUM OF 8" FROM "Z" COMPONENT.



PAC-200 FLASHING DETAILS

VALLEY DETAIL (One Piece)

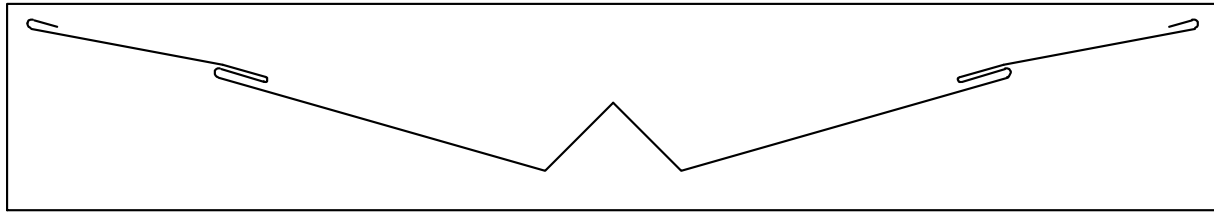

FLASHING COMPONENTS

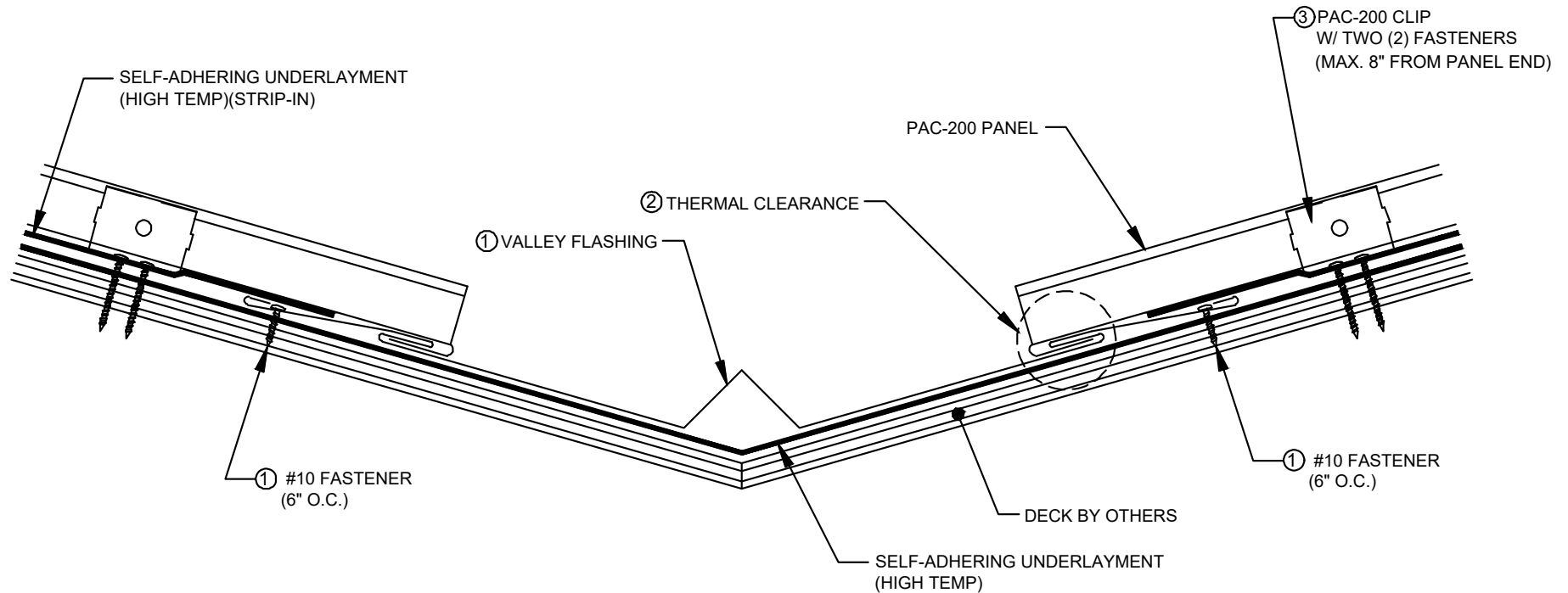

KEYNOTES:

- TRIM FASTENERS ARE SELF-DRILL PANCAKE HEAD AND MUST BE INSTALLED IN A STAGGERED PATTERN.
- CLIP AND FASTENER MATERIAL: GALVANIZED WHEN STEEL PANELS ARE UTILIZED; STAINLESS STEEL WHEN ALUMINUM PANELS ARE UTILIZED.
- CLIP FASTENERS MUST BE OF SUFFICIENT LENGTH TO PENETRATE PLYWOOD DECK BY 5/8" MINIMUM THREAD LENGTH.
- PLYWOOD DECK MUST BE A MINIMUM OF 5/8" THICK.

- ① VALLEY FLASHING FASTENED AT MAXIMUM 6" ON-CENTER SPACING.
- ② PANEL HEM THERMAL GAP CLEARANCE: MINIMUM 1 1/2" HEM WITH 1/2" CLEARANCE (CONSULT FACTORY).
- ③ FIRST PANEL CLIP TO BE LOCATED A MAXIMUM OF 8" FROM PANEL END.



PAC-200 FLASHING DETAILS

VALLEY DETAIL (Clip)

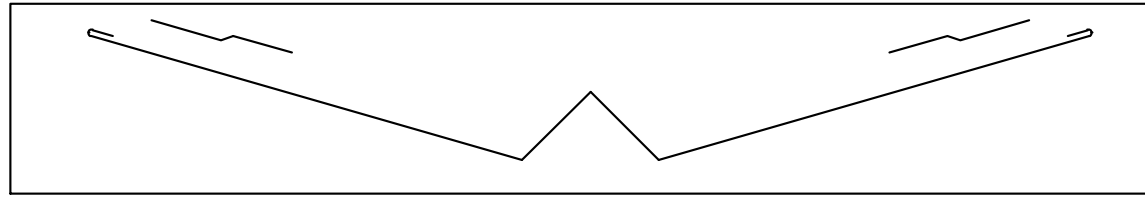

FLASHING COMPONENTS

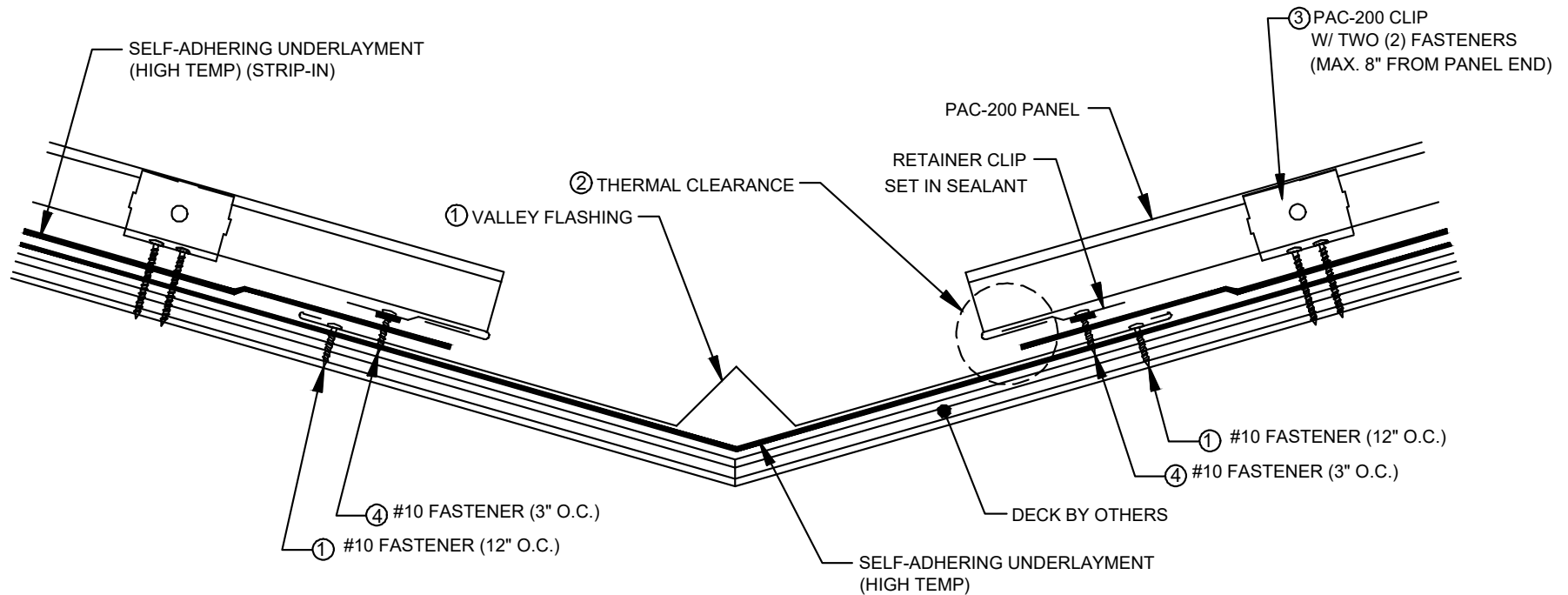

KEYNOTES:

- TRIM FASTENERS ARE SELF-DRILL PANCAKE HEAD AND MUST BE INSTALLED IN A STAGGERED PATTERN.
 - CLIP AND FASTENER MATERIAL: GALVANIZED WHEN STEEL PANELS ARE UTILIZED; STAINLESS STEEL WHEN ALUMINUM PANELS ARE UTILIZED.
 - CLIP FASTENERS MUST BE OF SUFFICIENT LENGTH TO PENETRATE PLYWOOD DECK BY 5/8" MINIMUM THREAD LENGTH.
 - PLYWOOD DECK MUST BE A MINIMUM OF 5/8" THICK.
- ① VALLEY FLASHING FASTENED AT MAXIMUM 12" ON-CENTER SPACING.
 - ② PANEL HEM THERMAL GAP CLEARANCE: MINIMUM 1 1/2" HEM WITH 1/2" CLEARANCE (CONSULT FACTORY).
 - ③ FIRST PANEL CLIP TO BE LOCATED A MAXIMUM OF 8" FROM PANEL END.
 - ④ RETAINER CLIP: FASTENED TO SUPPORT PLATE AT 3" O.C. STAGGERED PATTERN



PAC-200 FLASHING DETAILS

EAVE DETAIL - BULLNOSE

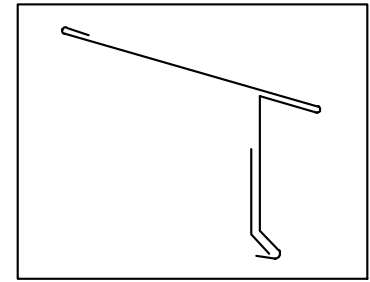
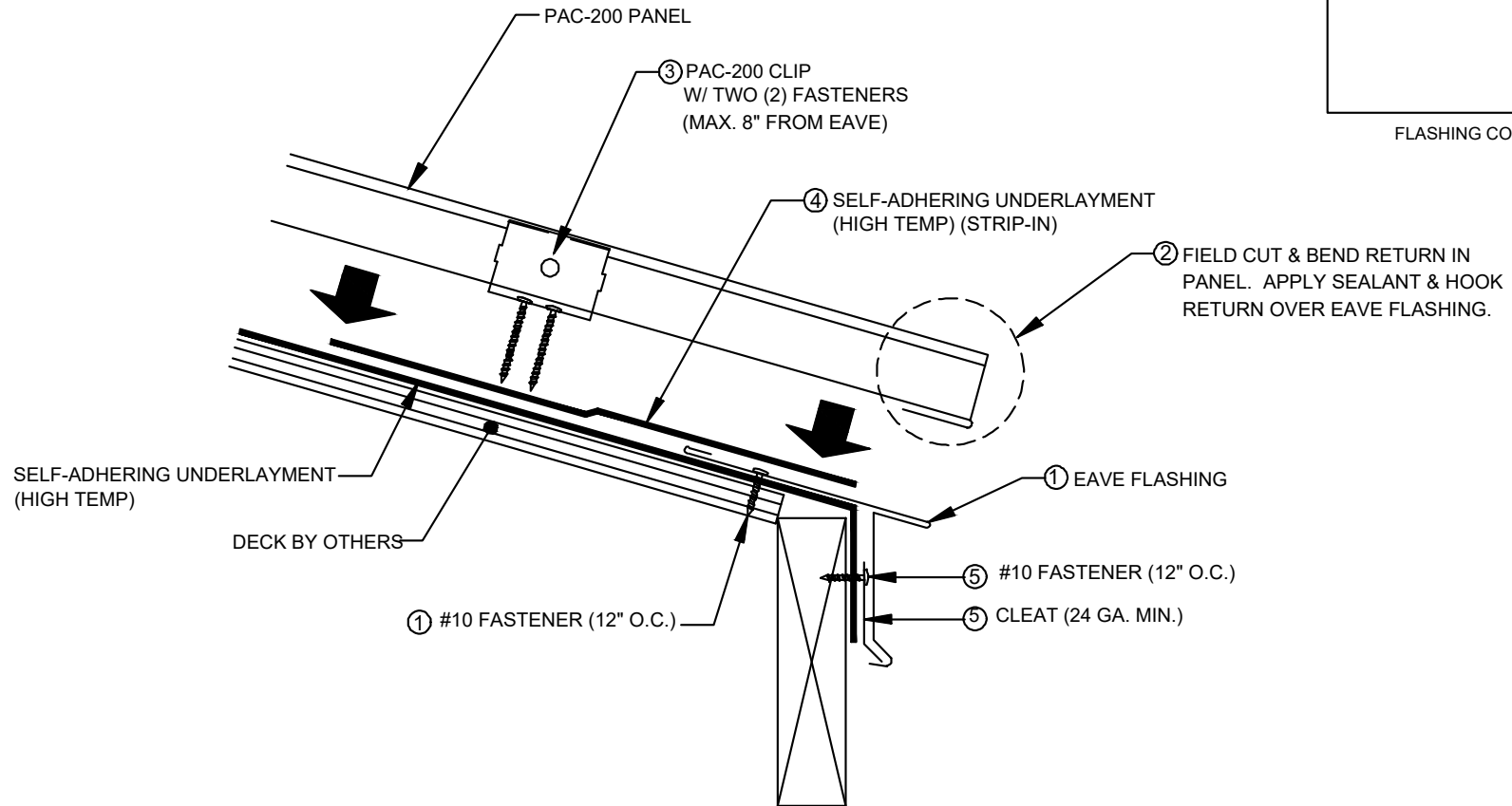

FLASHING COMPONENTS

KEYNOTES:

- TRIM FASTENERS ARE SELF-DRILL PANCAKE HEAD AND MUST BE INSTALLED IN A STAGGERED PATTERN.
 - CLIP AND FASTENER MATERIAL: GALVANIZED WHEN STEEL PANELS ARE UTILIZED; STAINLESS STEEL WHEN ALUMINUM PANELS ARE UTILIZED.
 - CLIP FASTENERS MUST BE OF SUFFICIENT LENGTH TO PENETRATE PLYWOOD DECK BY 5/8" MINIMUM THREAD LENGTH.
 - PLYWOOD DECK MUST BE A MINIMUM OF 5/8" THICK.
- ① EAVE FLASHING HEM EDGE: 1 1/2" MINIMUM.
 - ② PANEL HEM AND THERMAL GAP CLEARANCE: MINIMUM 1 1/2" HEM WITH 1/2" CLEARANCE. (CONSULT FACTORY).
 - ③ FIRST PANEL CLIP TO BE LOCATED A MAXIMUM OF 8" FROM EAVE.
 - ④ ROOF SIDE FLANGE SHOULD BE STRIPPED IN WITH APPROVED UNDERLAYMENT.
 - ⑤ CLEAT: 24 GA. MINIMUM.



PAC-200 FLASHING DETAILS

EAVE DETAIL-CLIP

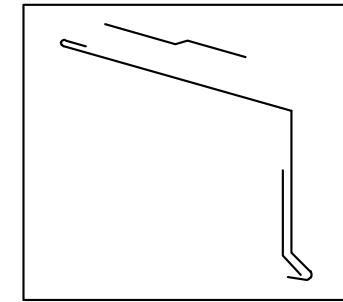
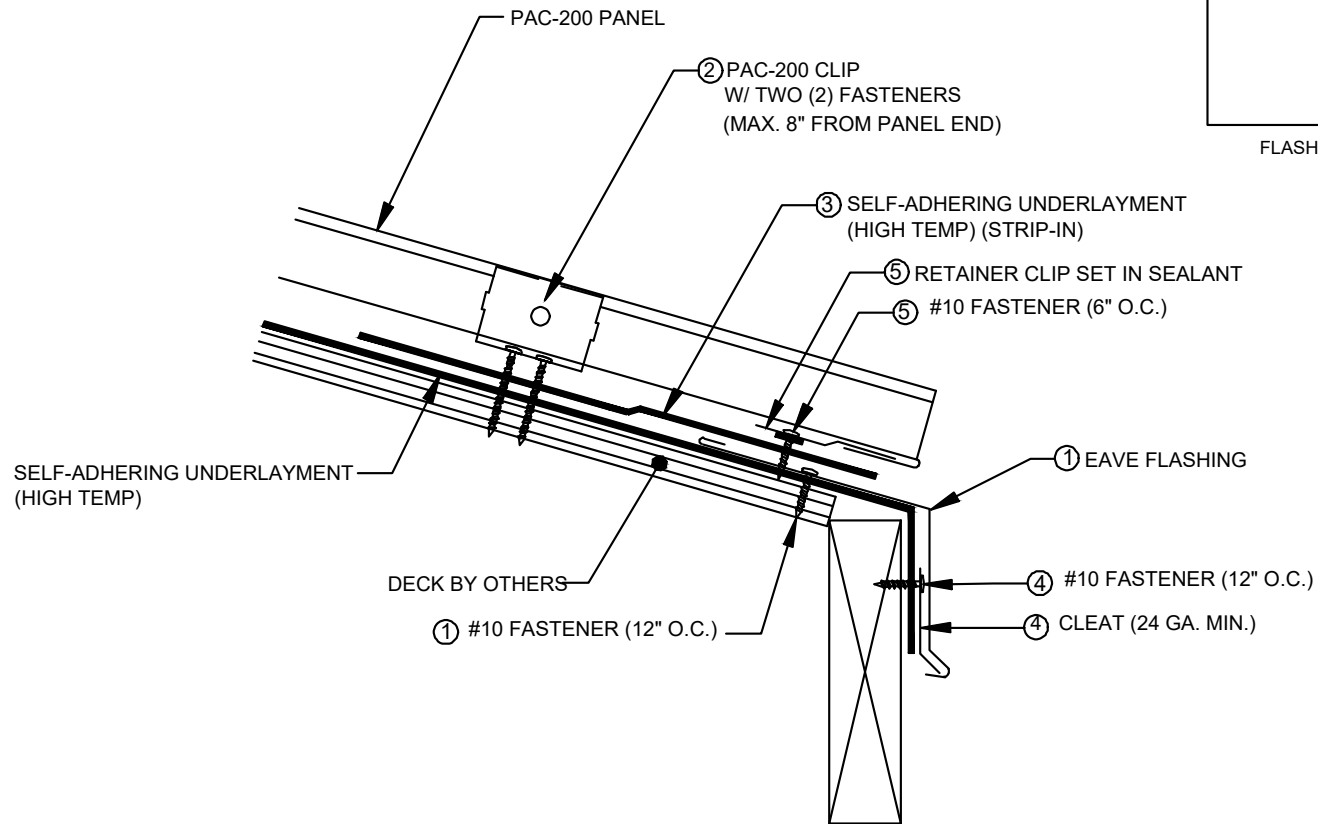

FLASHING COMPONENTS

KEYNOTES:

- TRIM FASTENERS ARE SELF-DRILL PANCAKE HEAD AND MUST BE INSTALLED IN A STAGGERED PATTERN.
 - CLIP AND FASTENER MATERIAL: GALVANIZED WHEN STEEL PANELS ARE UTILIZED; STAINLESS STEEL WHEN ALUMINUM PANELS ARE UTILIZED.
 - CLIP FASTENERS MUST BE OF SUFFICIENT LENGTH TO PENETRATE PLYWOOD DECK BY 5/8" MINIMUM THREAD LENGTH.
 - PLYWOOD DECK MUST BE A MINIMUM OF 5/8" THICK.
- ① EAVE FLASHING FASTENED AT 12" ON-CENTER MAXIMUM.
 - ② FIRST PANEL CLIP TO BE LOCATED A MAXIMUM OF 8" FROM EAVE.
 - ③ ROOF SIDE FLANGE SHOULD BE STRIPPED IN WITH APPROVED UNDERLAYMENT.
 - ④ CLEAT: 24 GA. MINIMUM.
 - ⑤ RETAINER CLIP: FASTENED TO SUPPORT PLATE AT 6" O.C. STAGGERED PATTERN.



PAC-200 FLASHING DETAILS

EAVE w/ FASCIA DETAIL

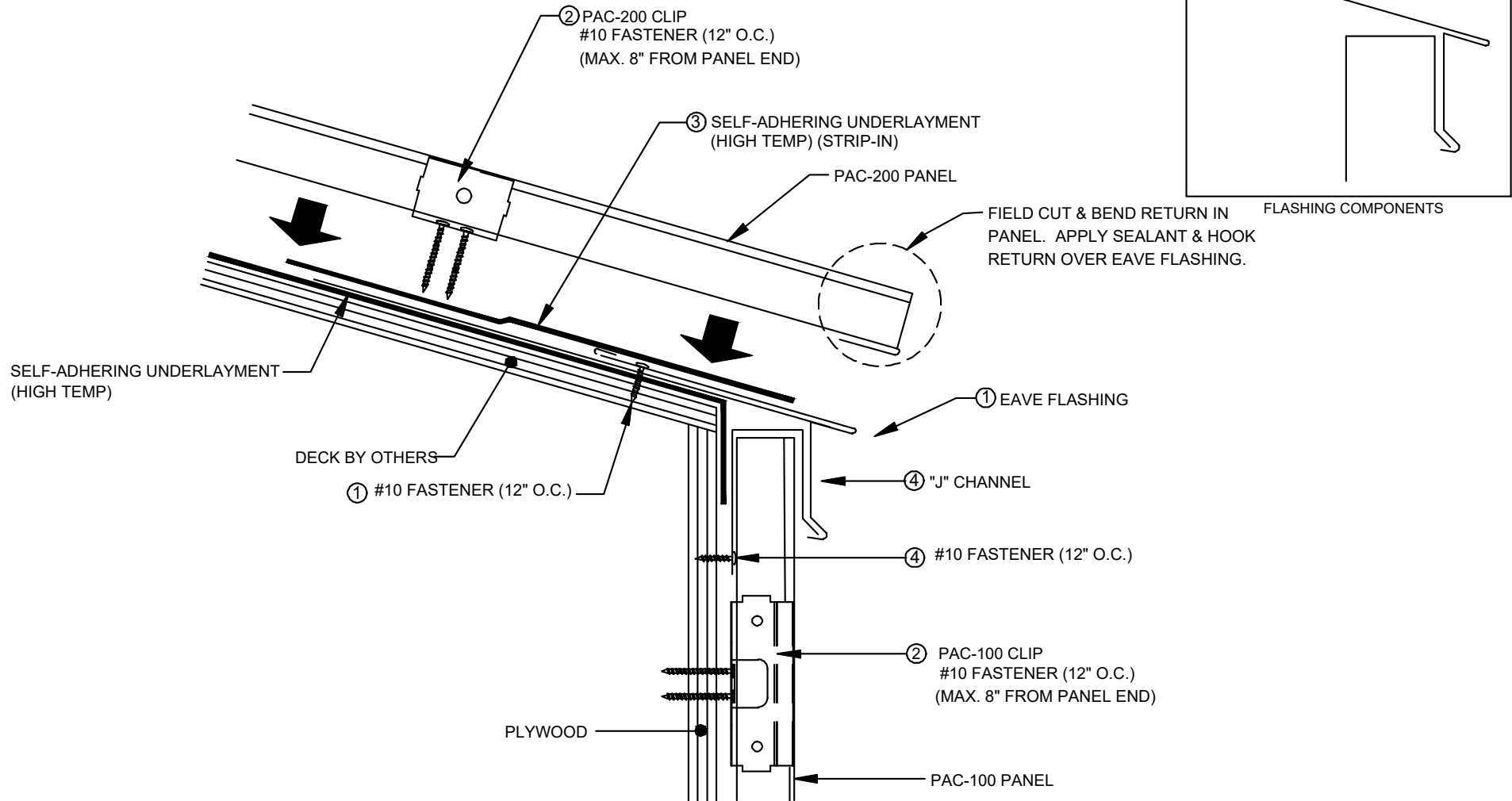

KEYNOTES:

- TRIM FASTENERS ARE SELF-DRILL PANCAKE HEAD AND MUST BE INSTALLED IN A STAGGERED PATTERN.
- CLIP AND FASTENER MATERIAL: GALVANIZED WHEN STEEL PANELS ARE UTILIZED; STAINLESS STEEL WHEN ALUMINUM PANELS ARE UTILIZED.
- CLIP FASTENERS MUST BE OF SUFFICIENT LENGTH TO PENETRATE PLYWOOD DECK BY 5/8" MINIMUM THREAD LENGTH.
- PLYWOOD DECK MUST BE A MINIMUM OF 5/8" THICK.

- ① EAVE FLASHING HEM EDGE: 1 1/2" MINIMUM.
- ② FIRST PANEL CLIP TO BE LOCATED A MAXIMUM OF 8" FROM PANEL END.
- ③ ROOF SIDE FLANGE SHOULD BE STRIPPED IN WITH APPROVED UNDERLAYMENT.
- ④ "J" CHANNEL: ATTACHED AT MAXIMUM 12" ON-CENTER.



PAC-200 FLASHING DETAILS

EAVE DETAIL W/ GUTTER

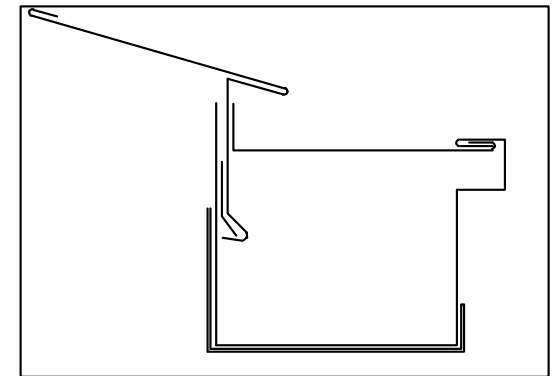
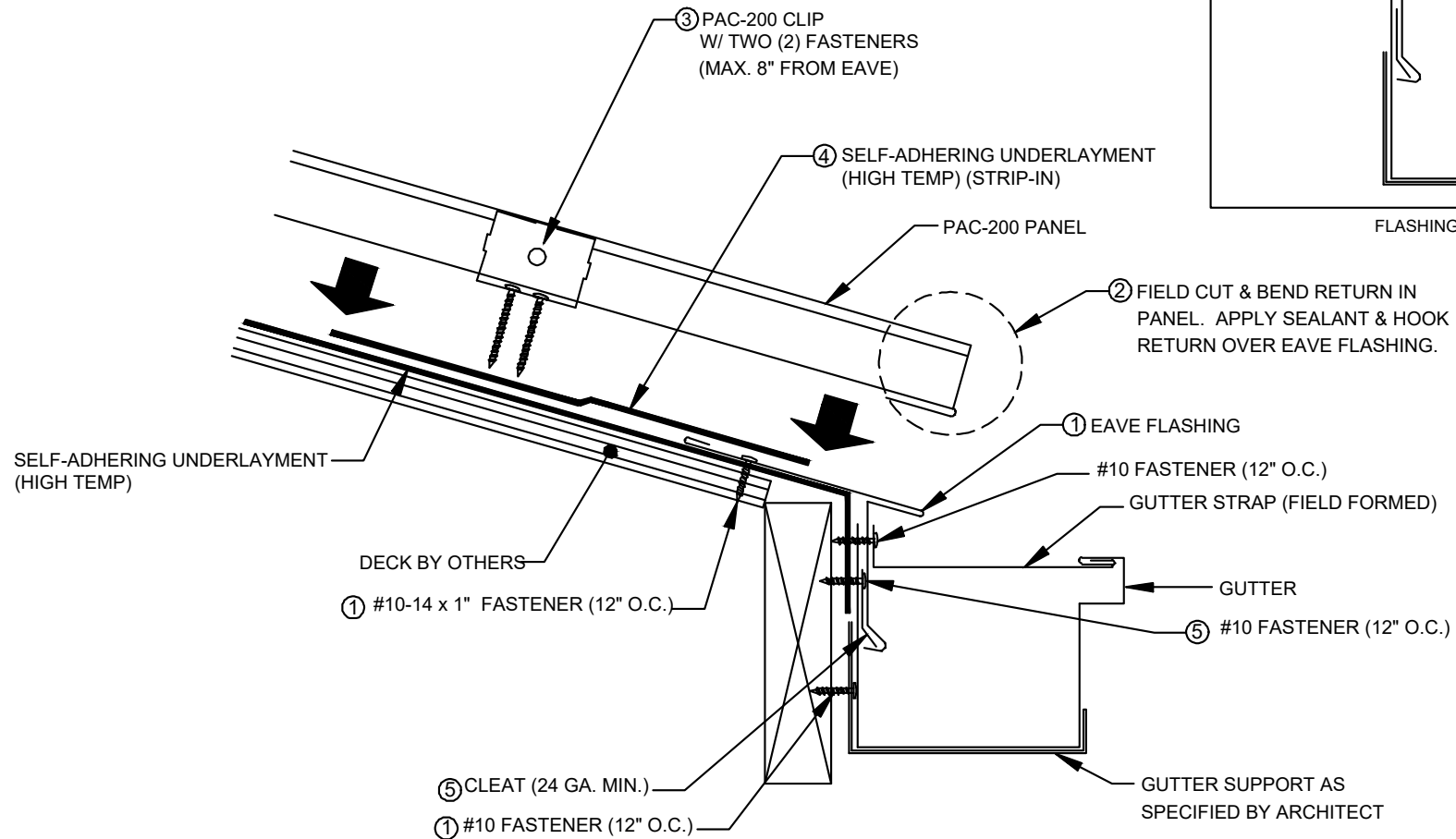

FLASHING COMPONENTS

KEYNOTES:

- TRIM FASTENERS ARE SELF-DRILL PANCAKE HEAD AND MUST BE INSTALLED IN A STAGGERED PATTERN.
- CLIP AND FASTENER MATERIAL: GALVANIZED WHEN STEEL PANELS ARE UTILIZED; STAINLESS STEEL WHEN ALUMINUM PANELS ARE UTILIZED.
- CLIP FASTENERS MUST BE OF SUFFICIENT LENGTH TO PENETRATE PLYWOOD DECK BY 5/8" MINIMUM THREAD LENGTH.
- PLYWOOD DECK MUST BE A MINIMUM OF 5/8" THICK.

- ① EAVE FLASHING HEM EDGE: 1 1/2" MINIMUM.
- ② PANEL HEM AND THERMAL GAP CLEARANCE: MINIMUM 1 1/2" HEM WITH 1/2" CLEARANCE. (CONSULT FACTORY).
- ③ FIRST PANEL CLIP TO BE LOCATED A MAXIMUM OF 8" FROM EAVE .
- ④ ROOF SIDE FLANGE SHOULD BE STRIPPED IN WITH APPROVED UNDERLAYMENT.
- ⑤ CLEAT: 24 GA. MINIMUM



PAC-200 FLASHING DETAILS

EAVE DETAIL W/ GUTTER

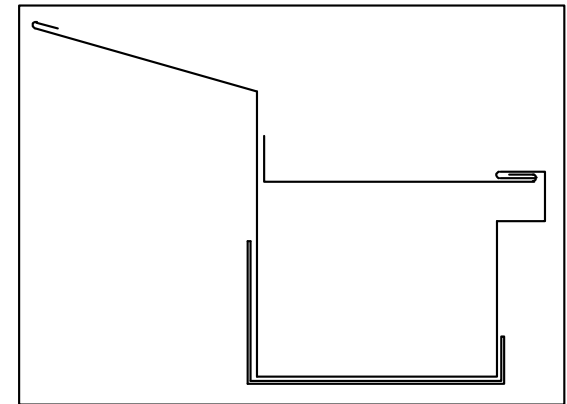
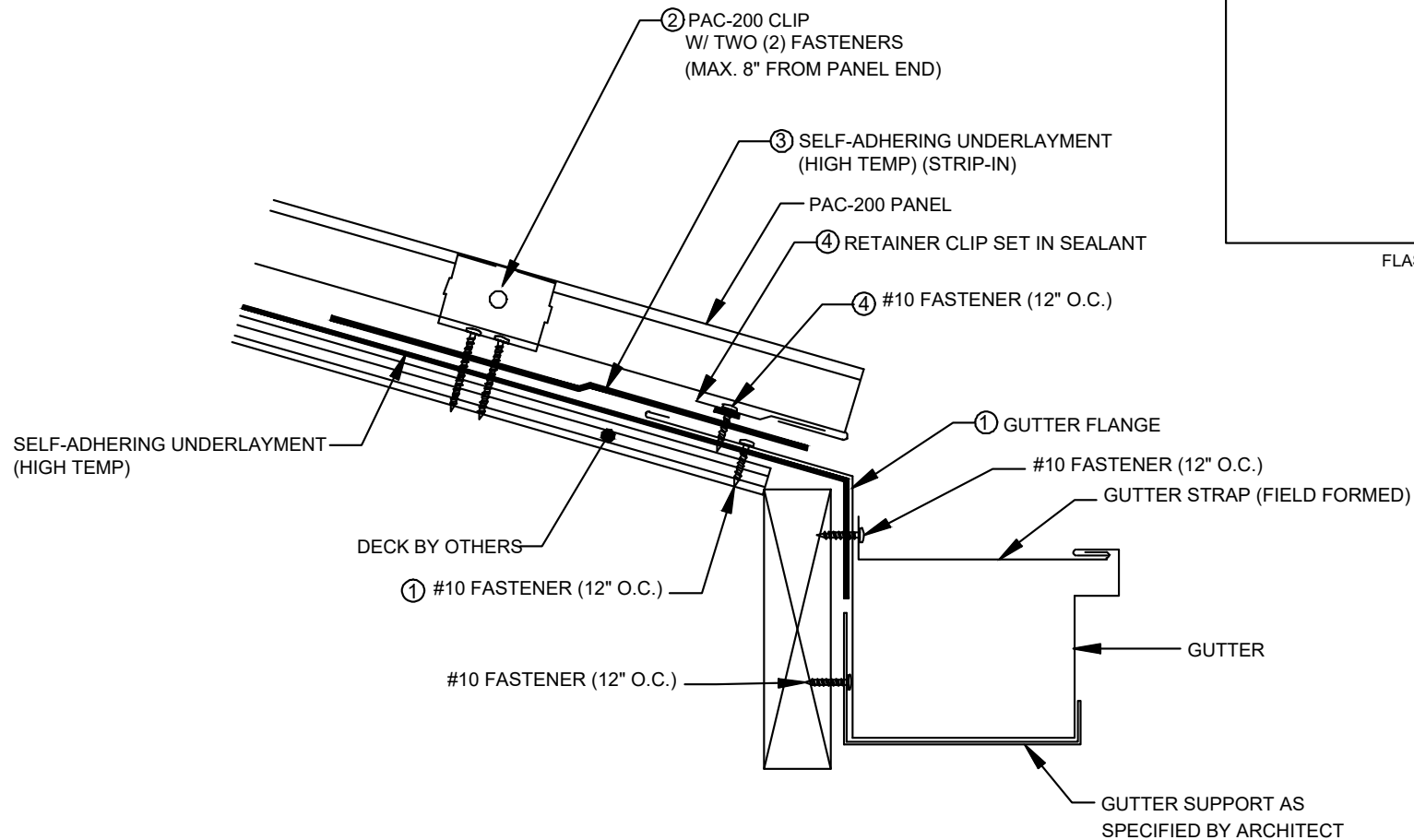

FLASHING COMPONENTS

KEYNOTES:

- TRIM FASTENERS ARE SELF-DRILL PANCAKE HEAD AND MUST BE INSTALLED IN A STAGGERED PATTERN.
- CLIP AND FASTENER MATERIAL: GALVANIZED WHEN STEEL PANELS ARE UTILIZED; STAINLESS STEEL WHEN ALUMINUM PANELS ARE UTILIZED.
- CLIP FASTENERS MUST BE OF SUFFICIENT LENGTH TO PENETRATE PLYWOOD DECK BY 5/8" MINIMUM THREAD LENGTH.
- PLYWOOD DECK MUST BE A MINIMUM OF 5/8" THICK.

- ① GUTTER FLANGE FASTENED AT MAXIMUM 12" ON-CENTER, STAGGERED PATTERN.
- ② FIRST PANEL CLIP TO BE LOCATED A MAXIMUM OF 8" FROM EAVE.
- ③ ROOF SIDE FLANGE SHOULD BE STRIPPED IN WITH APPROVED UNDERLAYMENT.
- ④ RETAINER CLIP: FASTENED TO SUPPORT PLATE AT 6" O.C., STAGGERED PATTERN.



PAC-200 FLASHING DETAILS

RAKE DETAIL

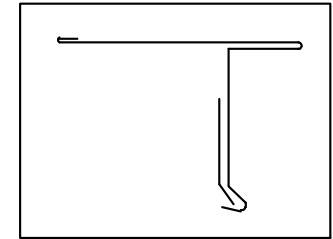

FLASHING COMPONENTS

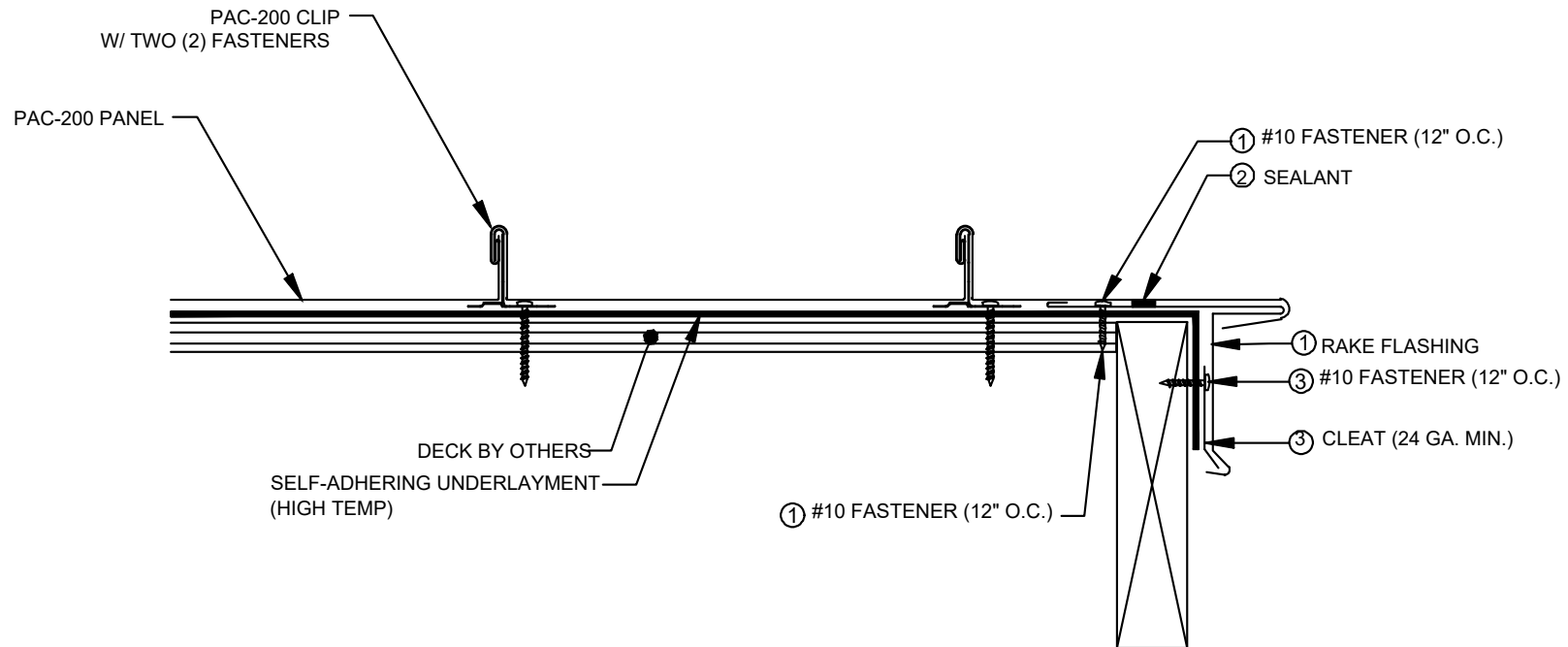

KEYNOTES:

- TRIM FASTENERS ARE SELF-DRILL PANCAKE HEAD AND MUST BE INSTALLED IN A STAGGERED PATTERN.
 - CLIP AND FASTENER MATERIAL: GALVANIZED WHEN STEEL PANELS ARE UTILIZED; STAINLESS STEEL WHEN ALUMINUM PANELS ARE UTILIZED.
 - CLIP FASTENERS MUST BE OF SUFFICIENT LENGTH TO PENETRATE PLYWOOD DECK BY 5/8" MINIMUM THREAD LENGTH.
 - PLYWOOD DECK MUST BE A MINIMUM OF 5/8" THICK.
- ① RAKE FLASHING:
- HEMMED DIMENSION: 1 1/2" MINIMUM; 2" MAXIMUM
 - DECK SIDE LEG SHOULD BE A MINIMUM OF 5" LONG WITH FASTENER LOCATED 2" MAXIMUM FROM EDGE.
 - PANEL HEM SHOULD BE CLOSED SECURELY TO HEM LEG OF RAKE FLASHING
- ② SEALANT CAN BE TUBE OR TAPE SEALANT AND MUST BE CONTINUOUS.
- ③ CLEAT: 24 GA. MINIMUM.



PAC-200 FLASHING DETAILS

RAKE DETAIL W/ "J" CLOSURE

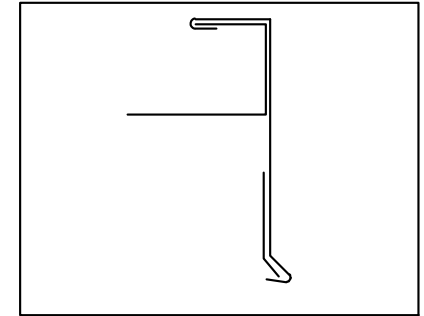

FLASHING COMPONENTS

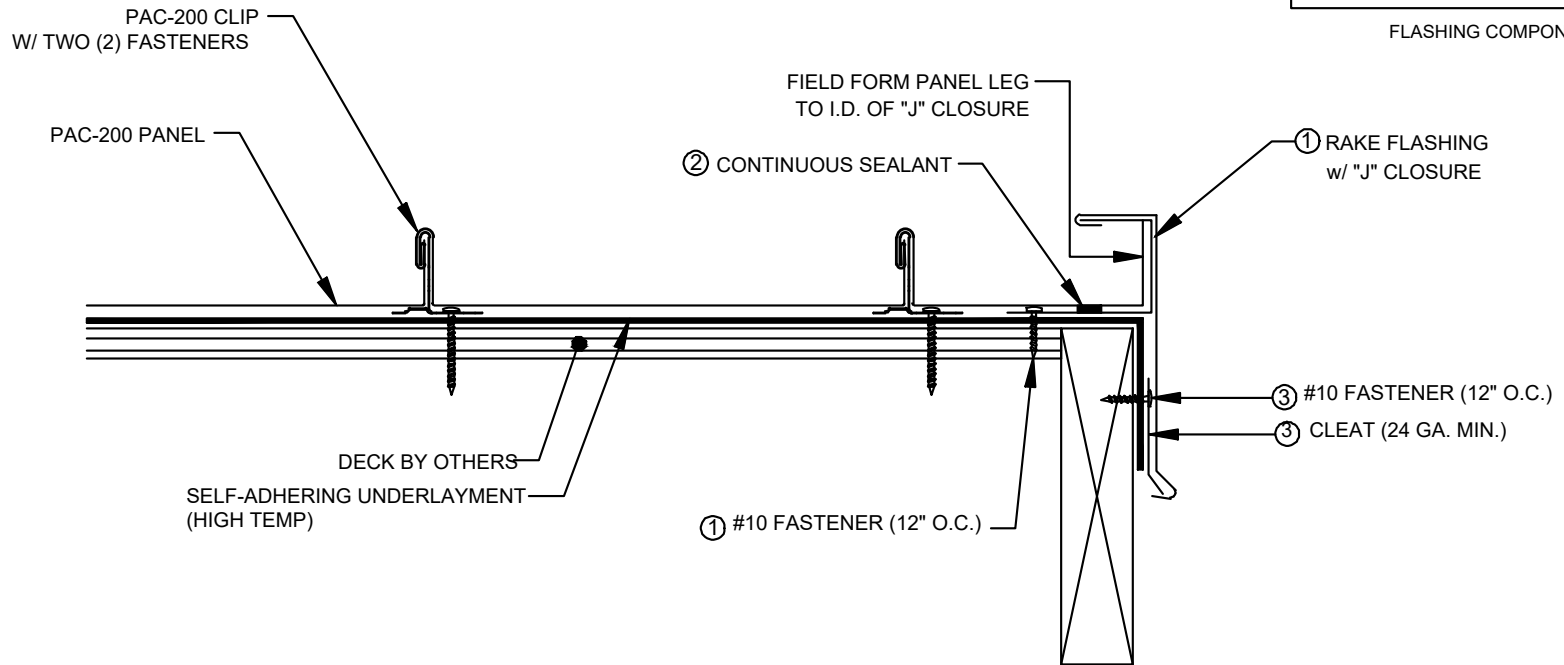

KEYNOTES: _____

- TRIM FASTENERS ARE SELF-DRILL PANCAKE HEAD AND MUST BE INSTALLED IN A STAGGERED PATTERN.
- CLIP AND FASTENER MATERIAL: GALVANIZED WHEN STEEL PANELS ARE UTILIZED; STAINLESS STEEL WHEN ALUMINUM PANELS ARE UTILIZED.
- CLIP FASTENERS MUST BE OF SUFFICIENT LENGTH TO PENETRATE PLYWOOD DECK BY 5/8" MINIMUM THREAD LENGTH.
- PLYWOOD DECK MUST BE A MINIMUM OF 5/8" THICK.

- ① RAKE FLASHING:
 - PANEL LEG MUST BE FORMED TO WITHIN 1/8" OF J-CHANNEL WEB.
 - DECK SIDE LEG SHOULD BE A MINIMUM OF 3" LONG WITH FASTENER LOCATED 2" MAXIMUM FROM EDGE.
 - J-CHANNEL FORMED TO HEIGHT OF PANEL RIB.
- ② SEALANT CAN BE TUBE OR TAPE SEALANT AND MUST BE CONTINUOUS.
- ③ CLEAT: 24 GA. MINIMUM.



PAC-200 FLASHING DETAILS

PEAK DETAIL

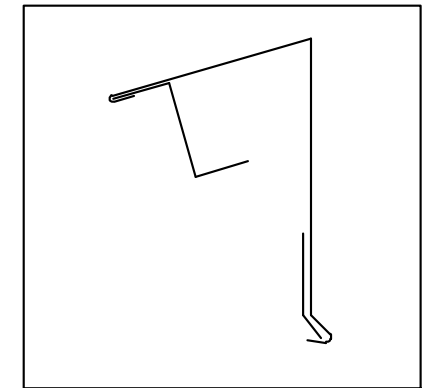
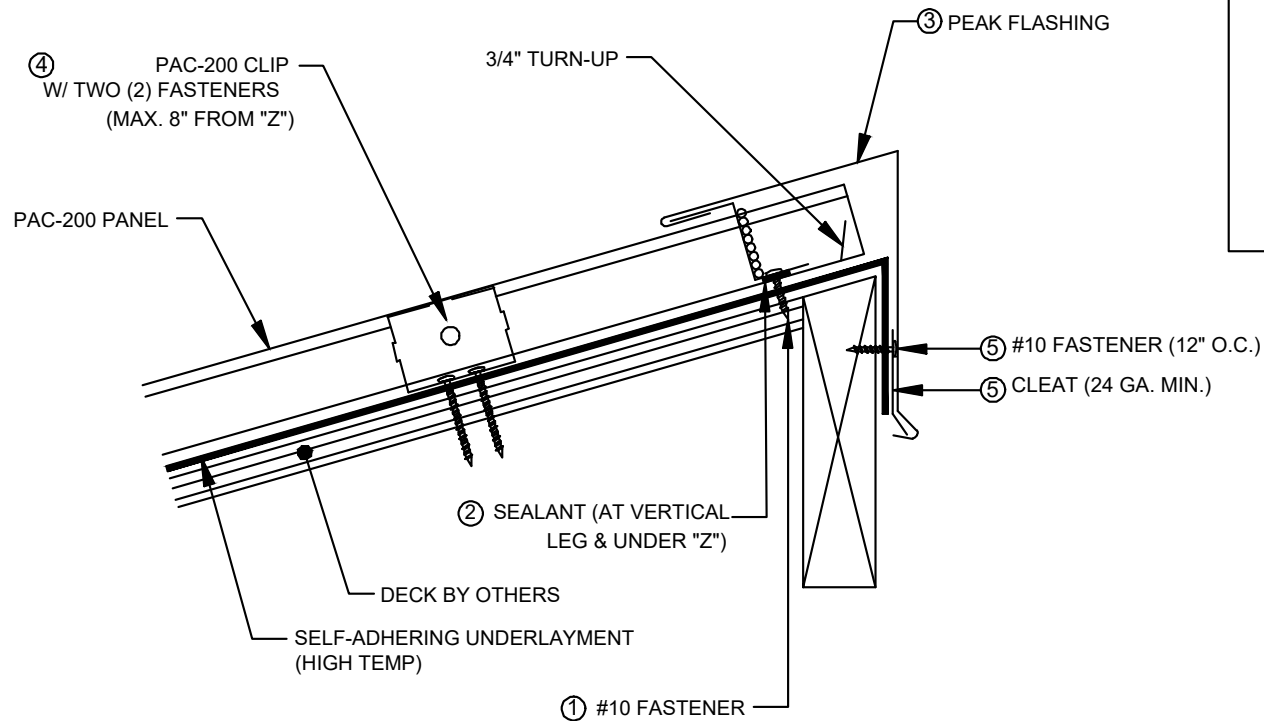

FLASHING COMPONENTS

KEYNOTES:

- TRIM FASTENERS ARE SELF-DRILL PANCAKE HEAD AND MUST BE INSTALLED IN A STAGGERED PATTERN.
- CLIP AND FASTENER MATERIAL: GALVANIZED WHEN STEEL PANELS ARE UTILIZED; STAINLESS STEEL WHEN ALUMINUM PANELS ARE UTILIZED.
- CLIP FASTENERS MUST BE OF SUFFICIENT LENGTH TO PENETRATE PLYWOOD DECK BY 5/8" MINIMUM THREAD LENGTH.
- PLYWOOD DECK MUST BE A MINIMUM OF 5/8" THICK.
- ① "Z" COMPONENT
 - MINIMUM HEIGHT: 1/8" CLEARANCE OF PANEL RIB
 - FASTENED AS FOLLOWS: 12" & 16" PANELS (4 FASTENERS PER PANEL MINIMUM); 18" PANELS (6 FASTENERS PER PANEL MINIMUM)
 - FASTENING LEG: 1 1/4" MINIMUM TOP LEG: 1 1/2" MINIMUM
 - "Z" MUST BE CUT TO TIGHT FIT OF PANEL DIMENSION: 1/8" MAXIMUM GAP
- ② SEALANT
 - TUBE OR TAPE SEALANT IS ACCEPTABLE BELOW THE "Z"
 - TUBE SEALANT PLACED AT BACKSIDE OF VERTICAL LEGS
 - 1" TAPE WIDTH OR 1/2" BEAD WIDTH PRIOR TO COMPRESSION
- ③ PEAK FLASHING: HEMMED 1" AND FULLY ENGAGED TO "Z" CLOSURE.
- ④ FIRST PANEL CLIP TO BE LOCATED A MAXIMUM OF 8" FROM "Z" COMPONENT.
- ⑤ CLEAT: 24 GA. MINIMUM.



PAC-200 FLASHING DETAILS

HEADWALL DETAIL W/ RECEIVER

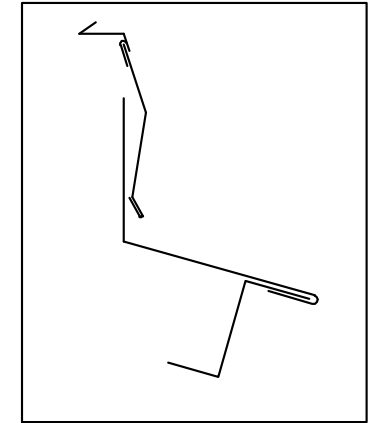
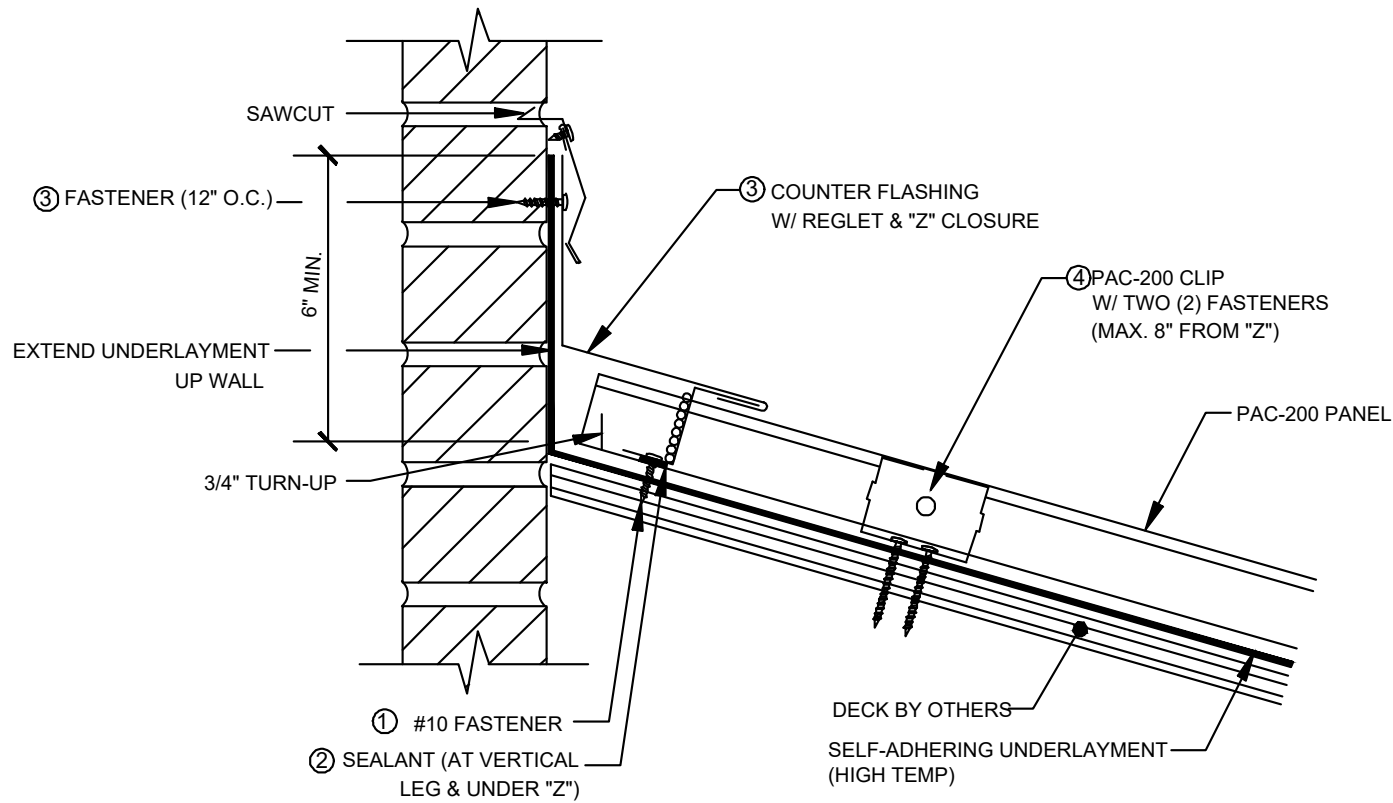

FLASHING COMPONENTS

KEYNOTES:

- TRIM FASTENERS ARE SELF-DRILL PANCAKE HEAD AND MUST BE INSTALLED IN A STAGGERED PATTERN.
 - CLIP AND FASTENER MATERIAL: GALVANIZED WHEN STEEL PANELS ARE UTILIZED; STAINLESS STEEL WHEN ALUMINUM PANELS ARE UTILIZED.
 - CLIP FASTENERS MUST BE OF SUFFICIENT LENGTH TO PENETRATE PLYWOOD DECK BY 5/8" MINIMUM THREAD LENGTH.
 - PLYWOOD DECK MUST BE A MINIMUM OF 5/8" THICK.
- ① "Z" COMPONENT
- MINIMUM HEIGHT: 1/8" CLEARANCE OF PANEL RIB
 - FASTENED AS FOLLOWS: 12" & 16" PANELS (4 FASTENERS PER PANEL MINIMUM); 18" PANELS (6 FASTENERS PER PANEL MINIMUM)
 - FASTENING LEG: 1 1/4" MINIMUM TOP LEG: 1 1/2" MINIMUM
 - "Z" MUST BE CUT TO TIGHT FIT OF PANEL DIMENSION: 1/8" MAXIMUM GAP
- ② SEALANT
- TUBE OR TAPE SEALANT IS ACCEPTABLE BELOW THE "Z"
 - TUBE SEALANT PLACED AT BACKSIDE OF VERTICAL LEGS
 - 1" TAPE WIDTH OR 1/2" BEAD WIDTH PRIOR TO COMPRESSION
- ③ COUNTER FLASHING: HEMMED 1" AND FULLY ENGAGED TO "Z" CLOSURE.
- ④ FIRST PANEL CLIP TO BE LOCATED A MAXIMUM OF 8" FROM "Z" COMPONENT.



PAC-200 FLASHING DETAILS

HEADWALL DETAIL

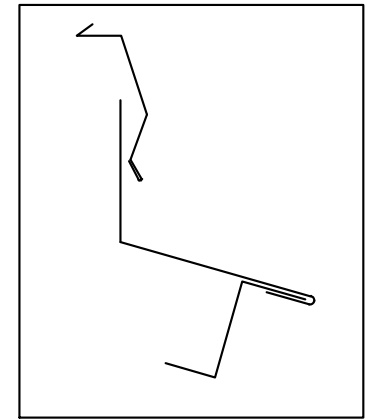
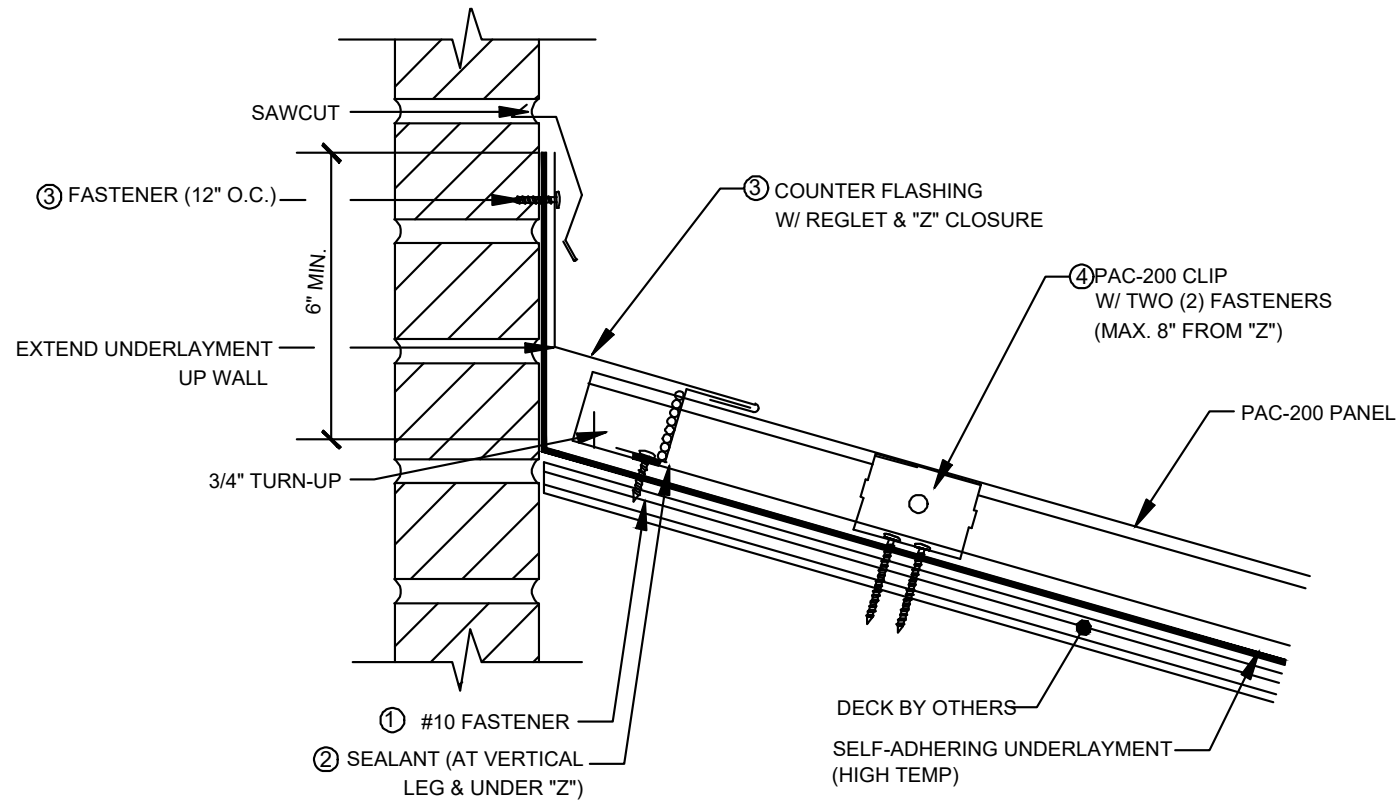

FLASHING COMPONENTS

KEYNOTES:

- TRIM FASTENERS ARE SELF-DRILL PANCAKE HEAD AND MUST BE INSTALLED IN A STAGGERED PATTERN.
- CLIP AND FASTENER MATERIAL: GALVANIZED WHEN STEEL PANELS ARE UTILIZED; STAINLESS STEEL WHEN ALUMINUM PANELS ARE UTILIZED.
- CLIP FASTENERS MUST BE OF SUFFICIENT LENGTH TO PENETRATE PLYWOOD DECK BY 5/8" MINIMUM THREAD LENGTH.
- PLYWOOD DECK MUST BE A MINIMUM OF 5/8" THICK.
- ① "Z" COMPONENT
 - MINIMUM HEIGHT: 1/8" CLEARANCE OF PANEL RIB
 - FASTENED AS FOLLOWS: 12" & 16" PANELS (4 FASTENERS PER PANEL MINIMUM); 18" PANELS (6 FASTENERS PER PANEL MINIMUM)
 - FASTENING LEG: 1 1/4" MINIMUM TOP LEG: 1 1/2" MINIMUM
 - "Z" MUST BE CUT TO TIGHT FIT OF PANEL DIMENSION: 1/8" MAXIMUM GAP
- ② SEALANT
 - TUBE OR TAPE SEALANT IS ACCEPTABLE BELOW THE "Z"
 - TUBE SEALANT PLACED AT BACKSIDE OF VERTICAL LEGS
 - 1" TAPE WIDTH OR 1/2" BEAD WIDTH PRIOR TO COMPRESSION
- ③ COUNTER FLASHING: HEMMED 1" AND FULLY ENGAGED TO "Z" CLOSURE.
- ④ FIRST PANEL CLIP TO BE LOCATED A MAXIMUM OF 8" FROM "Z" COMPONENT.



PAC-200 FLASHING DETAILS

RAKE WALL DETAIL W/ RECEIVER

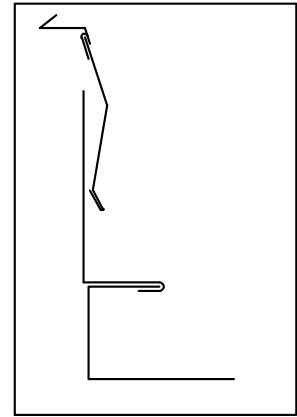

FLASHING COMPONENTS

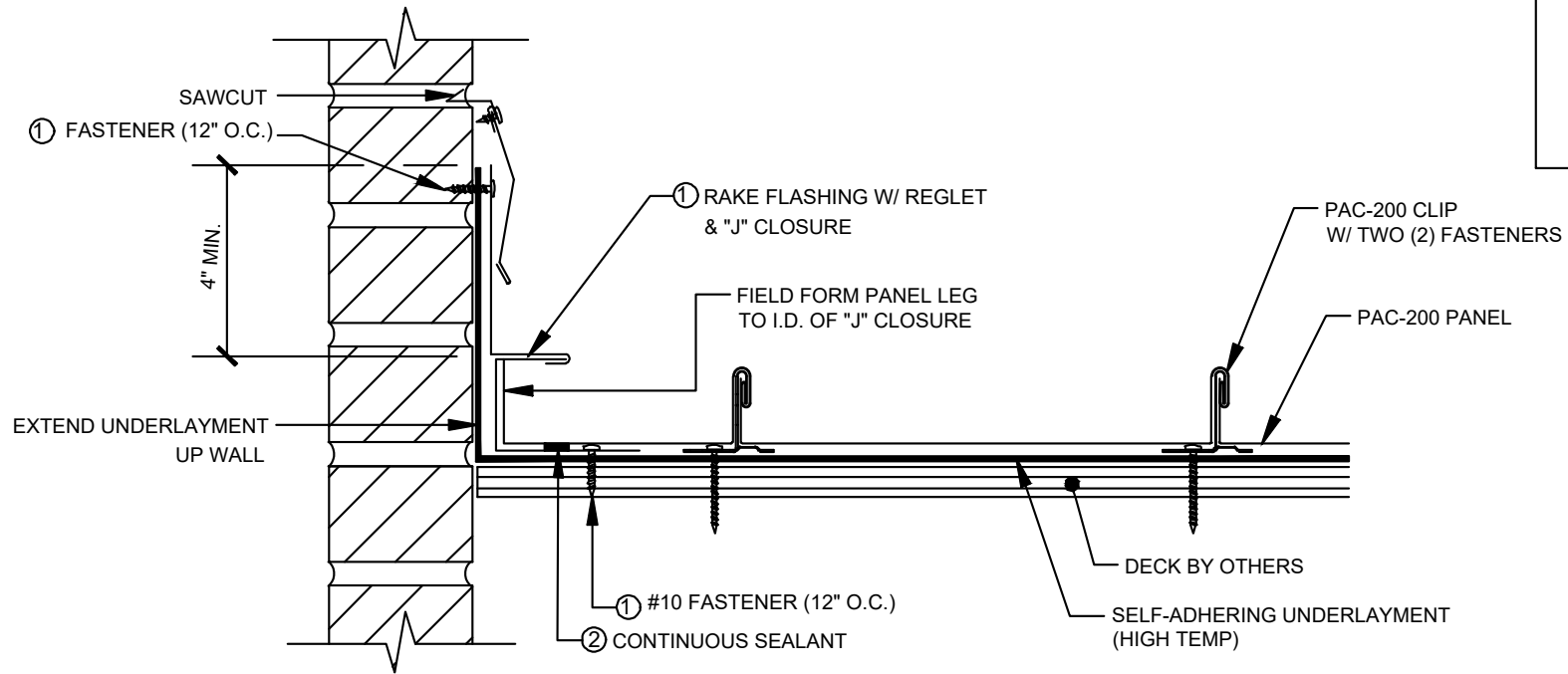

KEYNOTES:

- TRIM FASTENERS ARE SELF-DRILL PANCAKE HEAD AND MUST BE INSTALLED IN A STAGGERED PATTERN.
- CLIP AND FASTENER MATERIAL: GALVANIZED WHEN STEEL PANELS ARE UTILIZED; STAINLESS STEEL WHEN ALUMINUM PANELS ARE UTILIZED.
- CLIP FASTENERS MUST BE OF SUFFICIENT LENGTH TO PENETRATE PLYWOOD DECK BY 5/8" MINIMUM THREAD LENGTH.
- PLYWOOD DECK MUST BE A MINIMUM OF 5/8" THICK.
- ① RAKE FLASHING:
 - PANEL LEG MUST BE FORMED TO WITHIN 1/8" OF J-CHANNEL WEB.
 - DECK SIDE LEG SHOULD BE A MINIMUM OF 3" LONG WITH FASTENER LOCATED 2" MAXIMUM FROM EDGE.
 - J-CHANNEL FORMED TO HEIGHT OF PANEL RIB.
- ② SEALANT CAN BE TUBE OR TAPE SEALANT AND MUST BE CONTINUOUS.



PAC-200 FLASHING DETAILS

RAKE WALL DETAIL

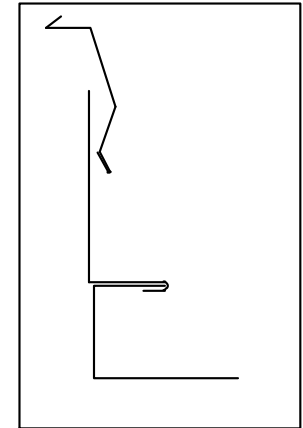
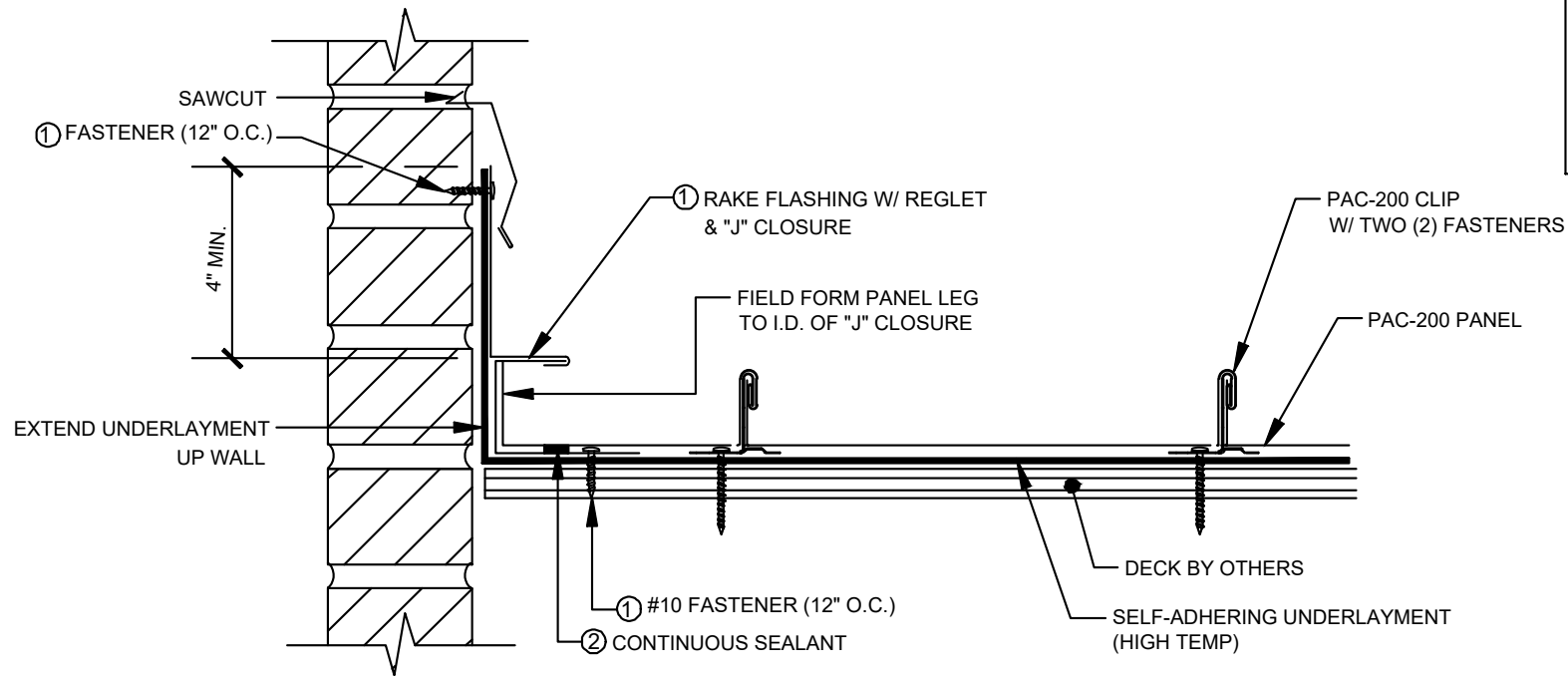

FLASHING COMPONENTS

KEYNOTES:

- TRIM FASTENERS ARE SELF-DRILL PANCAKE HEAD AND MUST BE INSTALLED IN A STAGGERED PATTERN.
- CLIP AND FASTENER MATERIAL: GALVANIZED WHEN STEEL PANELS ARE UTILIZED; STAINLESS STEEL WHEN ALUMINUM PANELS ARE UTILIZED.
- CLIP FASTENERS MUST BE OF SUFFICIENT LENGTH TO PENETRATE PLYWOOD DECK BY 5/8" MINIMUM THREAD LENGTH.
- PLYWOOD DECK MUST BE A MINIMUM OF 5/8" THICK.
- ① RAKE FLASHING:
 - PANEL LEG MUST BE FORMED TO WITHIN 1/8" OF J-CHANNEL WEB.
 - DECK SIDE LEG SHOULD BE A MINIMUM OF 3" LONG WITH FASTENER LOCATED 2" MAXIMUM FROM EDGE.
 - J-CHANNEL FORMED TO HEIGHT OF PANEL RIB.
- ② SEALANT CAN BE TUBE OR TAPE SEALANT AND MUST BE CONTINUOUS.



PAC-200 FLASHING DETAILS

RAKE WALL w/ FASCIA DETAIL

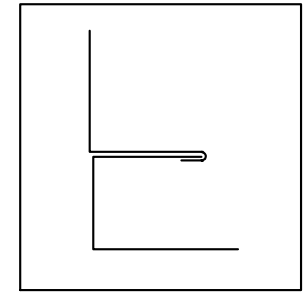
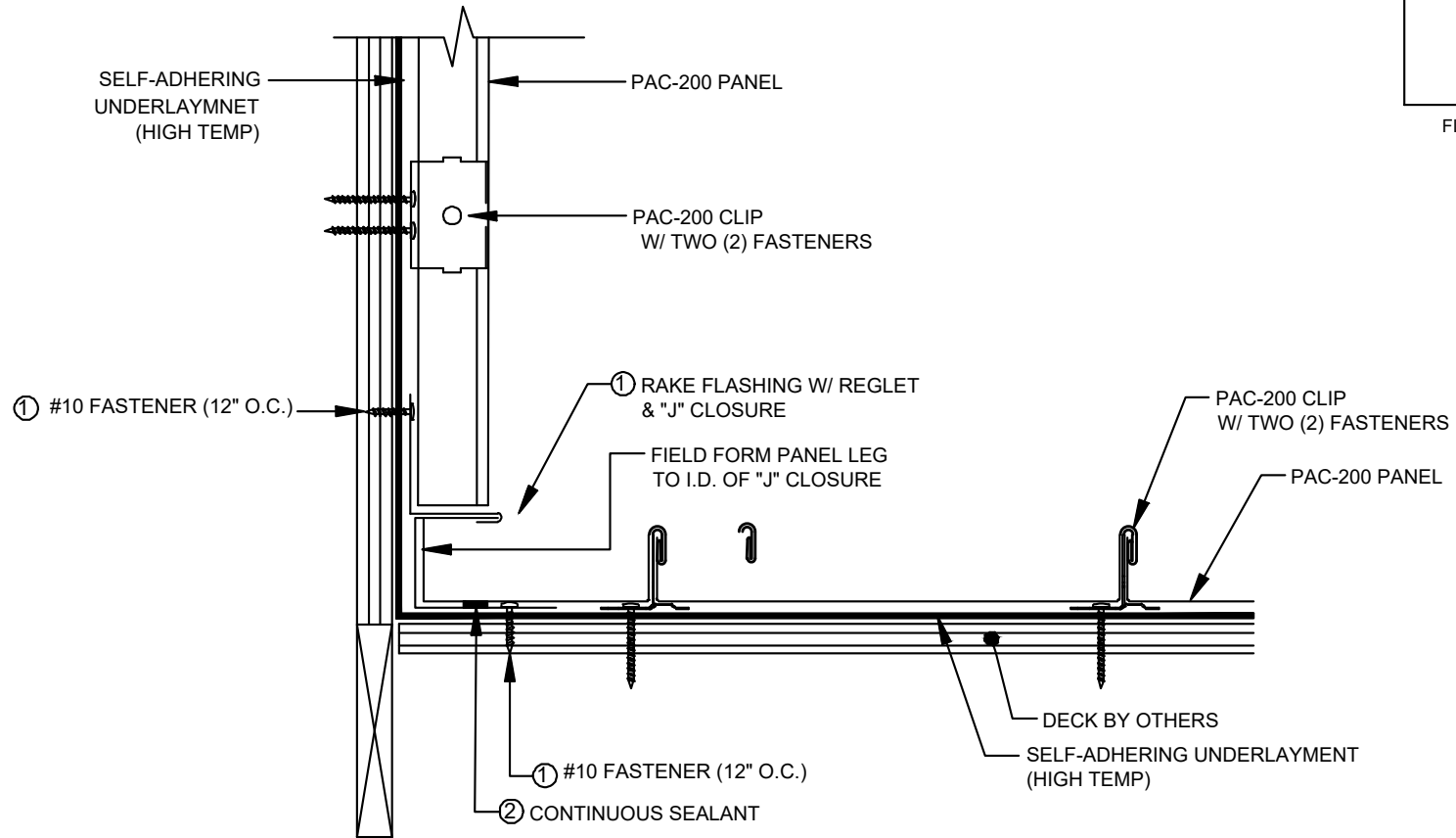

FLASHING COMPONENTS

KEYNOTES:

- TRIM FASTENERS ARE SELF-DRILL PANCAKE HEAD AND MUST BE INSTALLED IN A STAGGERED PATTERN.
- CLIP AND FASTENER MATERIAL: GALVANIZED WHEN STEEL PANELS ARE UTILIZED; STAINLESS STEEL WHEN ALUMINUM PANELS ARE UTILIZED.
- CLIP FASTENERS MUST BE OF SUFFICIENT LENGTH TO PENETRATE PLYWOOD DECK BY 5/8" MINIMUM THREAD LENGTH.
- PLYWOOD DECK MUST BE A MINIMUM OF 5/8" THICK.
- ① RAKE FLASHING:
 - PANEL LEG MUST BE FORMED TO WITHIN 1/8" OF J-CHANNEL WEB.
 - DECK SIDE LEG SHOULD BE A MINIMUM OF 3" LONG WITH FASTENER LOCATED 2" MAXIMUM FROM EDGE.
 - J-CHANNEL FORMED TO HEIGHT OF PANEL RIB.
- ② SEALANT CAN BE TUBE OR TAPE SEALANT AND MUST BE CONTINUOUS.



PAC-200 FLASHING DETAILS

ROOF TRANSITION DETAIL

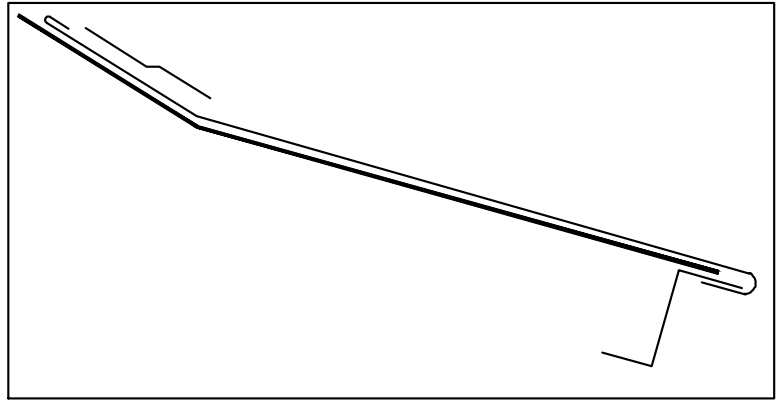
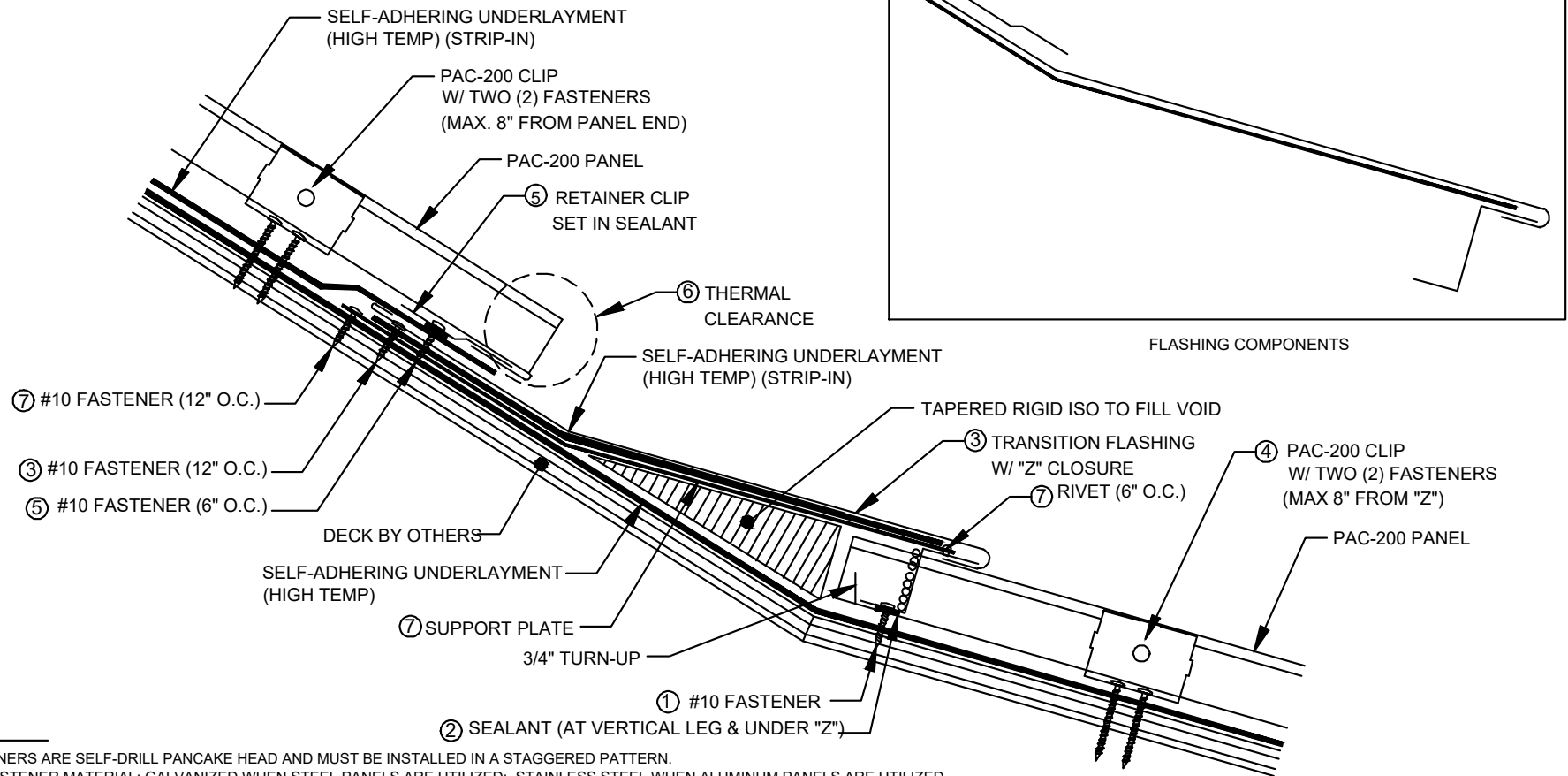

KEYNOTES:

- TRIM FASTENERS ARE SELF-DRILL PANCAKE HEAD AND MUST BE INSTALLED IN A STAGGERED PATTERN.
 - CLIP AND FASTENER MATERIAL: GALVANIZED WHEN STEEL PANELS ARE UTILIZED; STAINLESS STEEL WHEN ALUMINUM PANELS ARE UTILIZED.
 - CLIP FASTENERS MUST BE OF SUFFICIENT LENGTH TO PENETRATE PLYWOOD DECK BY 5/8" MINIMUM THREAD LENGTH.
 - PLYWOOD DECK MUST BE A MINIMUM OF 5/8" THICK.
- ① "Z" COMPONENT
 - MINIMUM HEIGHT: 1/8" CLEARANCE OF PANEL RIB
 - FASTENED AS FOLLOWS: 12" & 16" PANELS (4 FASTENERS PER PANEL MINIMUM); 18" PANELS (6 FASTENERS PER PANEL MINIMUM)
 - FASTENING LEG: 1 1/4" MINIMUM TOP LEG: 1 1/2" MINIMUM
 - "Z" MUST BE CUT TO TIGHT FIT OF PANEL DIMENSION: 1/8" MAXIMUM GAP
 - ② SEALANT
 - TUBE OR TAPE SEALANT IS ACCEPTABLE BELOW THE "Z"
 - TUBE SEALANT PLACED AT BACKSIDE OF VERTICAL LEGS
 - 1" TAPE WIDTH OR 1/2" BEAD WIDTH PRIOR TO COMPRESSION
 - ③ TRANSITION FLASHING: HEMMED 1" AND FULLY ENGAGED TO "Z" CLOSURE.
 - ④ FIRST PANEL CLIP TO BE LOCATED A MAXIMUM OF 8" FROM "Z" COMPONENT.
 - ⑤ RETAINER CLIP: FASTENED TO SUPPORT PLATE AT 6" O.C. STAGGERED PATTERN.
 - ⑥ PANEL HEM THERMAL GAP CLEARANCE: MINIMUM 1 1/2" HEM WITH 1/2" CLEARANCE (CONSULT FACTORY)
 - ⑦ SUPPORT PLATE: 20 GA. MINIMUM



PAC-200 FLASHING DETAILS

FASCIA TO SOFFIT DETAIL

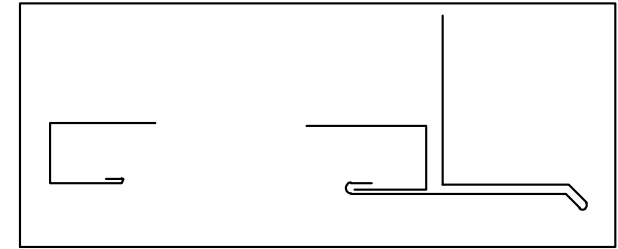

FLASHING COMPONENTS

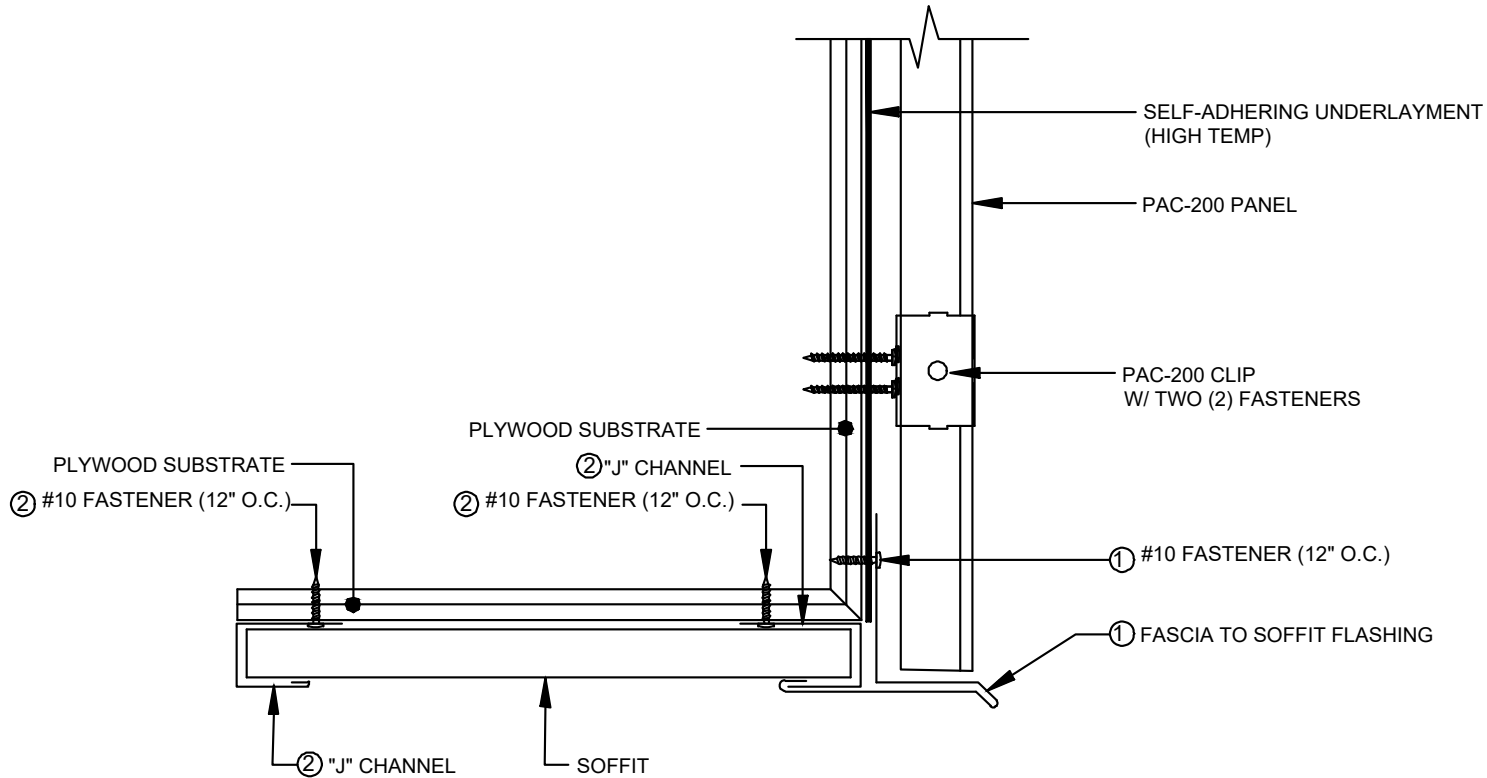

KEYNOTES:

- TRIM FASTENERS ARE SELF-DRILL PANCAKE HEAD AND MUST BE INSTALLED IN A STAGGERED PATTERN.
- CLIPS AND FASTENERS MATERIAL: GALVANIZED WHEN STEEL PANELS ARE UTILIZED; STAINLESS STEEL WHEN ALUMINUM PANELS ARE UTILIZED.
- ① FASCIA TO SOFFIT FLASHING:
 - FASTENED WITH #10 FASTENER AT MAXIMUM 12" ON-CENTER (STAGGERED PATTERN).
 - VERTICAL LEG SHOULD BE A MINIMUM OF 3" LONG WITH FASTENER LOCATED 2" MAXIMUM FROM EDGE.
- ② "J" CHANNEL: FASTENED WITH #10 FASTENER AT MAXIMUM 12" ON-CENTER (STAGGERED PATTERN).



PAC-200 FLASHING DETAILS

SILL DETAIL

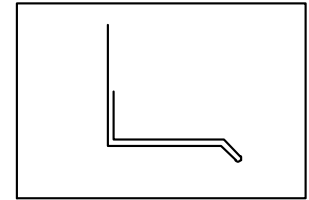

FLASHING COMPONENTS

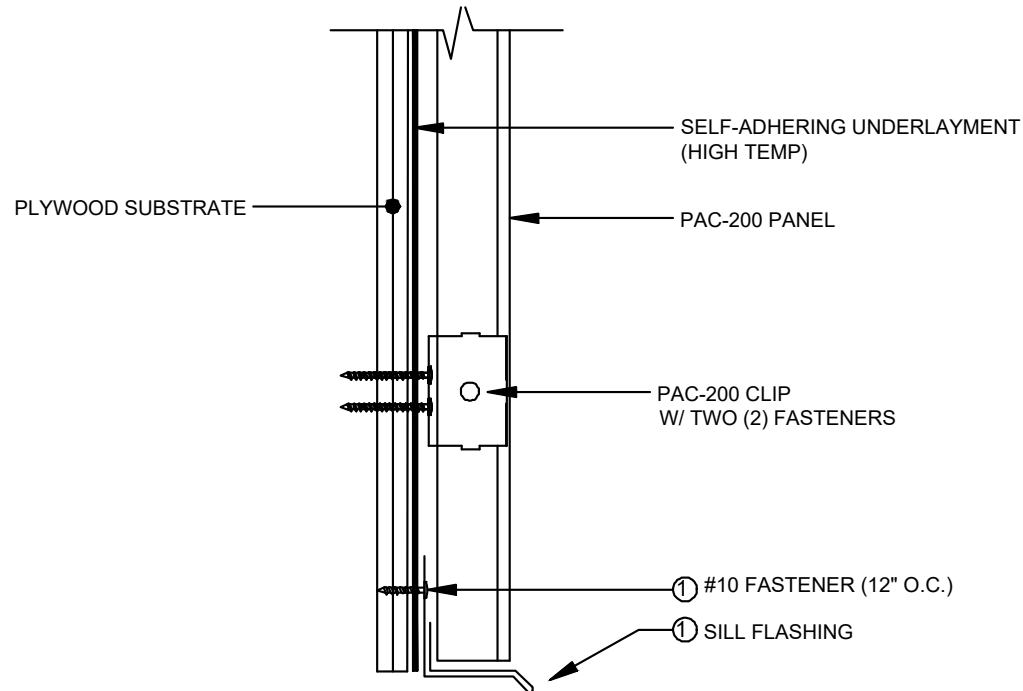

KEYNOTES:

- TRIM FASTENERS ARE SELF-DRILL PANCAKE HEAD AND MUST BE INSTALLED IN A STAGGERED PATTERN.
- CLIPS AND FASTENERS MATERIAL: GALVANIZED WHEN STEEL PANELS ARE UTILIZED; STAINLESS STEEL WHEN ALUMINUM PANELS ARE UTILIZED.
- ① SILL FLASHING: FASTENED WITH #10 FASTENER AT MAXIMUM 12" ON-CENTER (STAGGERED PATTERN).



PAC-200 FLASHING DETAILS

OUTSIDE CORNER DETAIL

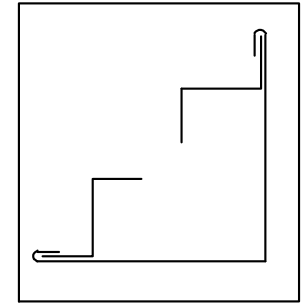
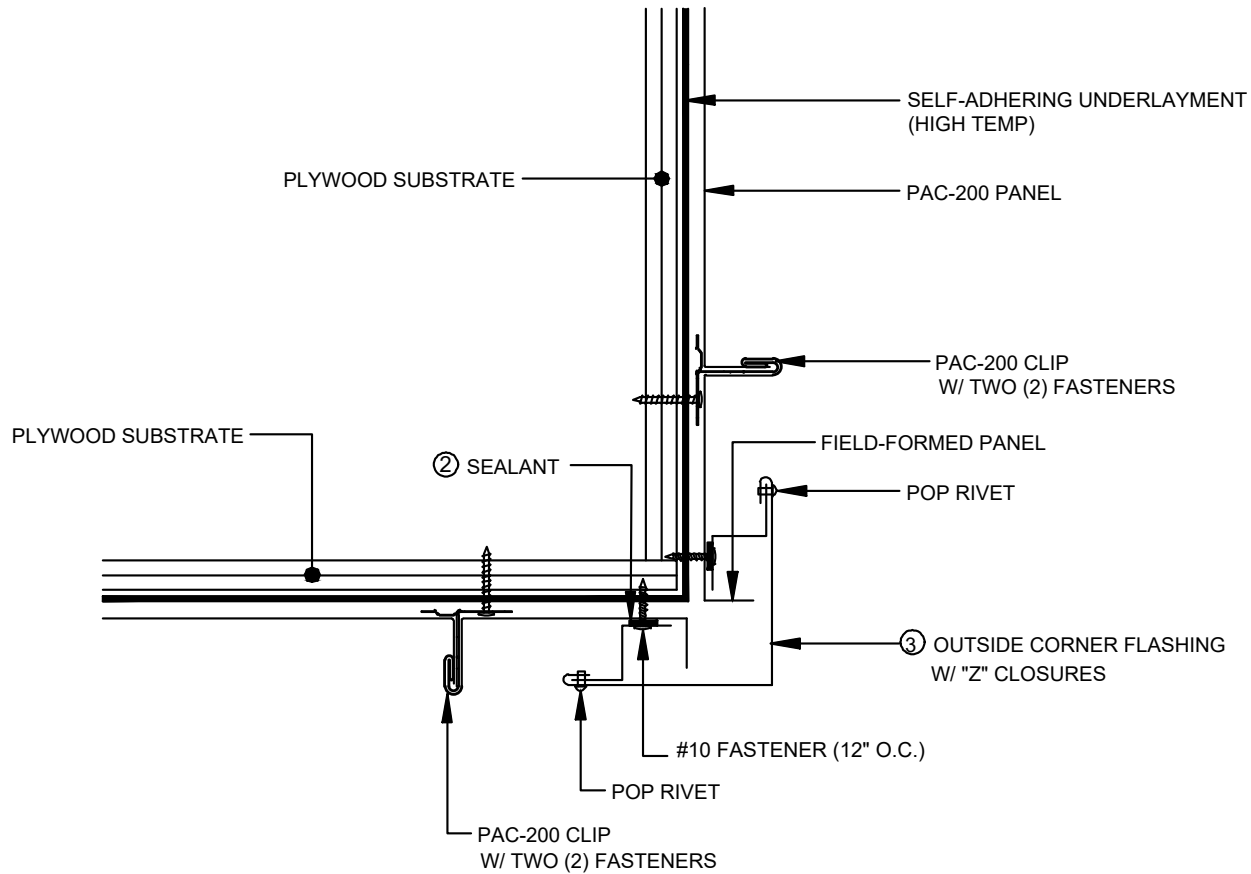

FLASHING COMPONENTS

KEYNOTES:

- TRIM FASTENERS ARE SELF-DRILL PANCAKE HEAD AND MUST BE INSTALLED IN A STAGGERED PATTERN.
 - CLIPS AND FASTENERS MATERIAL: GALVANIZED WHEN STEEL PANELS ARE UTILIZED; STAINLESS STEEL WHEN ALUMINUM PANELS ARE UTILIZED.
- ① "Z" COMPONENT
 - MINIMUM HEIGHT: 1/8" CLEARANCE OF PANEL RIB
 - FASTENING LEG: 1 1/4" MINIMUM TOP LEG: 1 1/2" MINIMUM
 - ② SEALANT
 - TUBE OR TAPE SEALANT IS ACCEPTABLE BELOW THE "Z"
 - 1" TAPE WIDTH OR 1/2" BEAD WIDTH PRIOR TO COMPRESSION
 - ③ OUTSIDE CORNER FLASHING
 - HEMMED 1" AND FULLY ENGAGED TO "Z" CLOSURE.



PAC-200 FLASHING DETAILS

INSIDE CORNER DETAIL

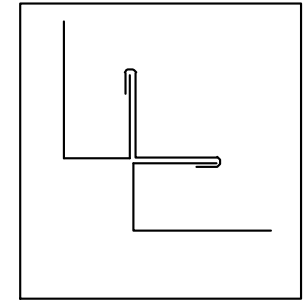

FLASHING COMPONENTS

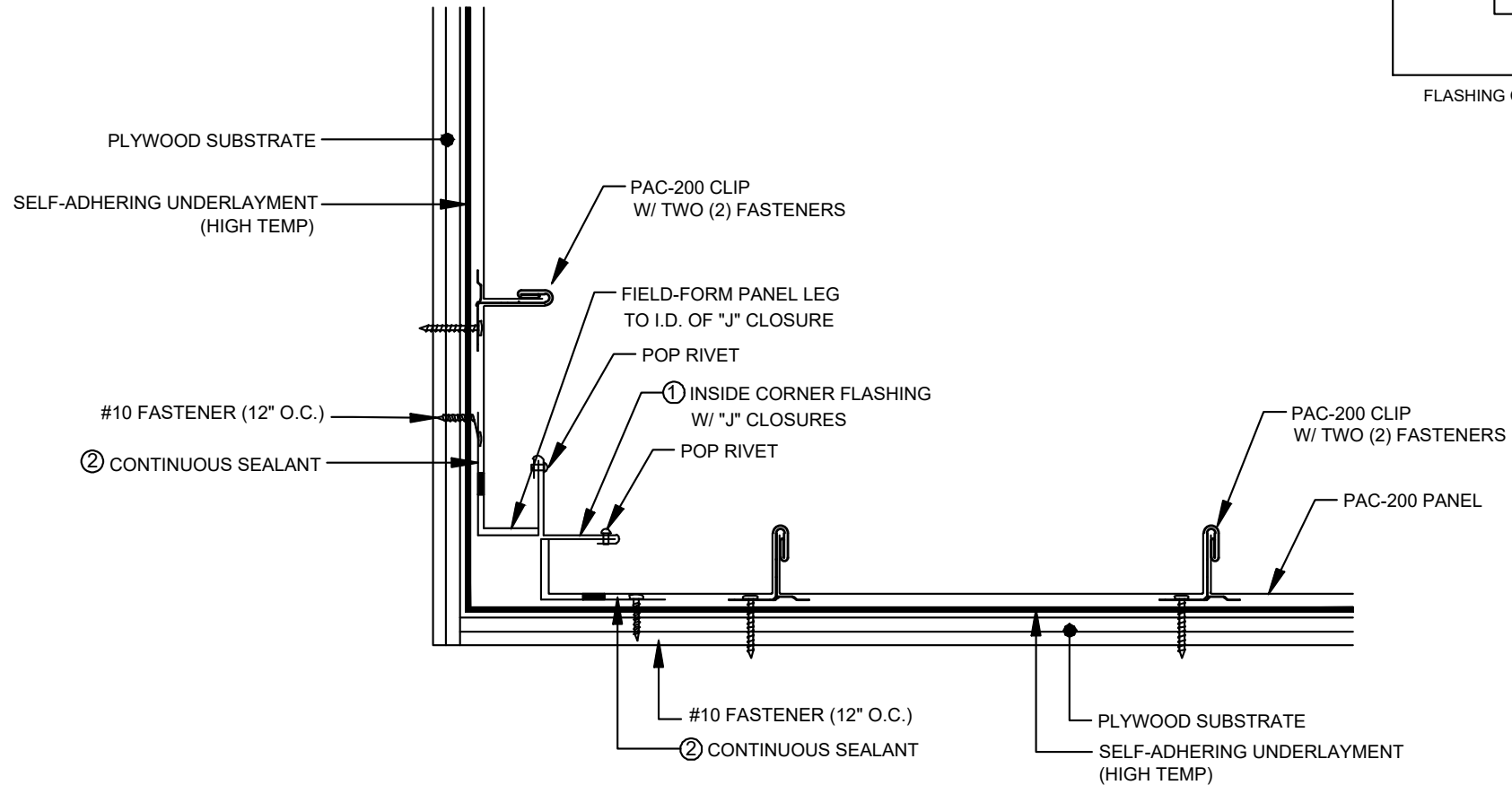

KEYNOTES:

- TRIM FASTENERS ARE SELF-DRILL PANCAKE HEAD AND MUST BE INSTALLED IN A STAGGERED PATTERN.
- CLIPS AND FASTENERS MATERIAL: GALVANIZED WHEN STEEL PANELS ARE UTILIZED; STAINLESS STEEL WHEN ALUMINUM PANELS ARE UTILIZED.
- ① INSIDE CORNER FLASHING
 - PANEL LEG MUST BE FORMED TO WITHIN 1/8" OF J-CHANNEL WEB.
 - DECK SIDE LEG SHOULD BE A MINIMUM OF 3" LONG WITH FASTENER LOCATED 2" MAXIMUM FROM EDGE.
 - J-CHANNEL FORMED TO HEIGHT OF PANEL RIB.
- ② SEALANT CAN BE TUBE OR TAPE SEALANT AND MUST BE CONTINUOUS.



PAC-200 FLASHING DETAILS

PANEL LAP DETAIL

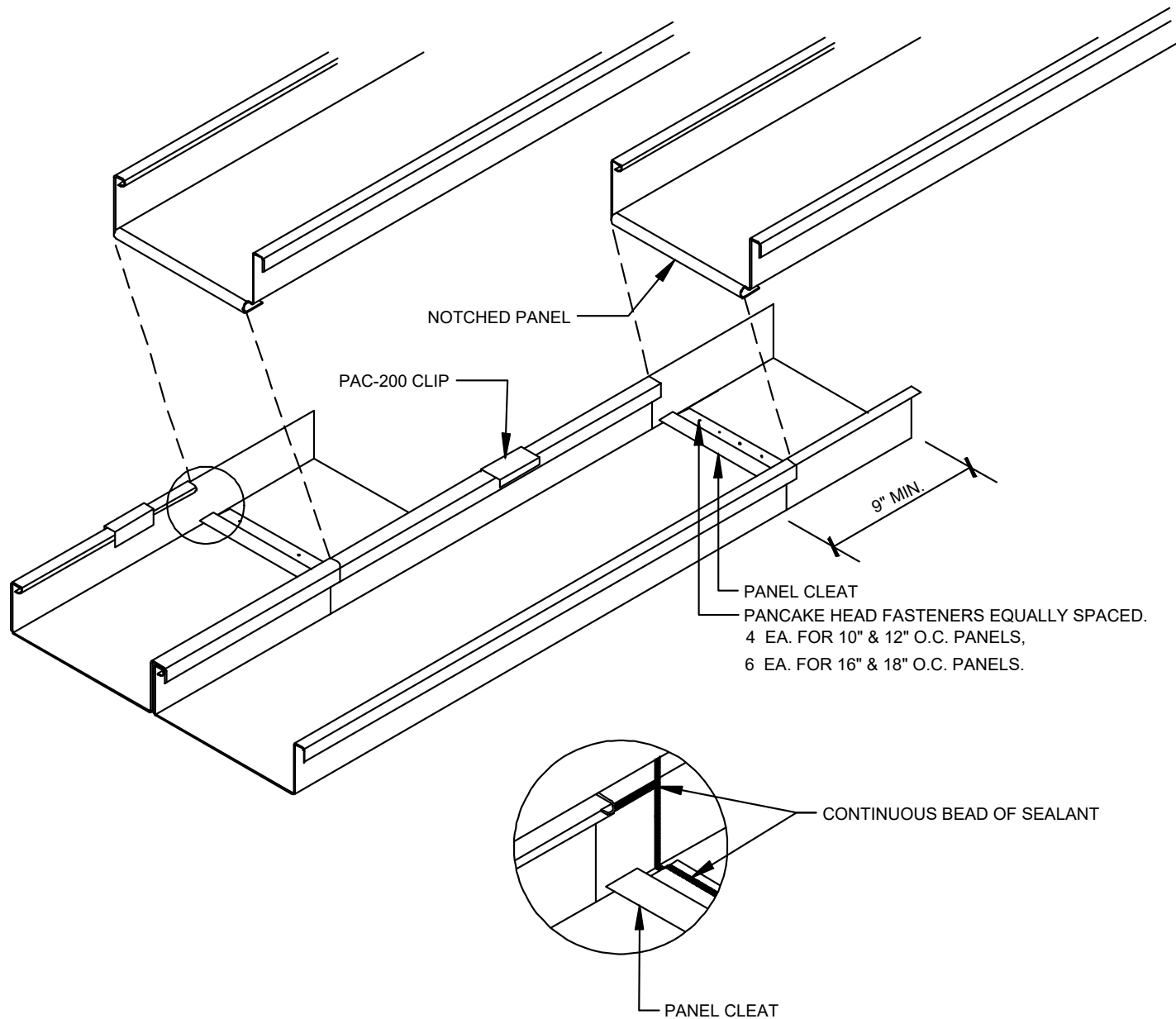

NOTE: LAPS MUST BE STAGGERED 2' OR 4'.



PAC-200 FLASHING DETAILS

FIELD BEND PANEL DETAIL

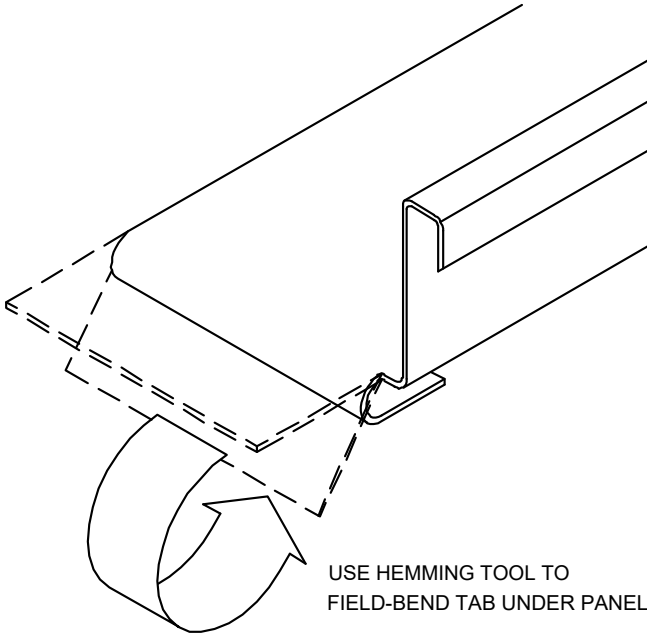
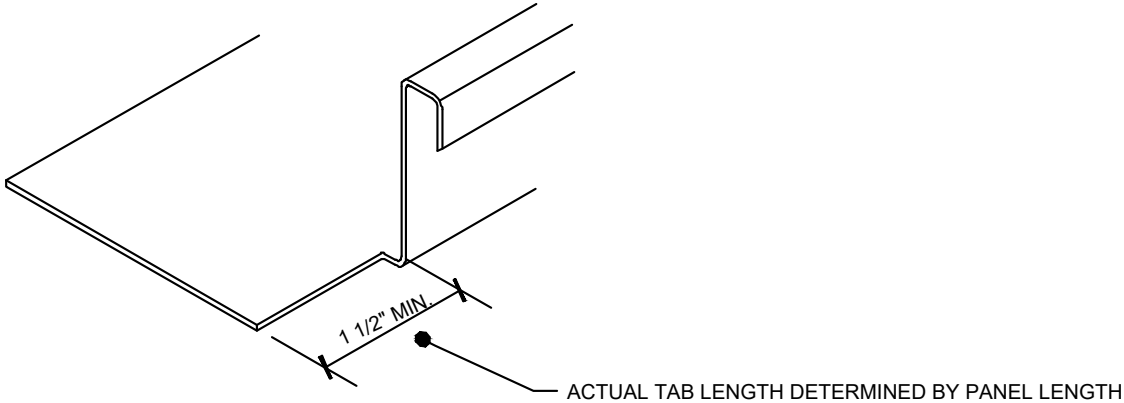

PAC-200 FLASHING DETAILS